

CHEMPRO®

THE TRANSPORTER OF
CORROSIVE CHEMICALS
PRODUCT CATALOGUE



CONTENTS



03

ABOUT ASTRAL

04

INNOVATION &
RECOGNITIONS

05

MARKETING
NETWORK

06

ABOUT CPVC |
ABOUT ASTRAL
CHEMPRO

07

WHY ASTRAL
CHEMPRO

08

ADVANTAGES

10

GENERAL
SPECIFICATIONS

11

WELD LINE
IN MOLDED FITTINGS,
CAUTIONS/
LIMITATIONS

12

THE IDEAL
CHOICE FOR

13

BASIC
PHYSICAL
PROPERTIES

14

DIMENSIONS

16

CPVC SCH 40 & SCH 80
PIPES & FITTINGS

17

COMPREHENSIVE
VALVE RANGE

20

THERMAL EXPANSION
AND CONTRACTION

22

INSTALLATION
PROCEDURE

25

JOINING ASTRAL
CHEMPRO CPVC PIPE
AND FITTINGS –
SOLVENT CEMENTING

27

GENERAL INSTALLATION
GUIDELINES, FLANGING
OF ASTRAL CHEMPRO
CPVC PIPE

29

TECHNICAL
INFORMATION

30

UNDERGROUND
INSTALLATION
GUIDELINES

31

FOR ALL
INSTALLATIONS

32

COMPARISON OF
CHEMPRO WITH MSRL

34

COMPARISON OF
CHEMPRO WITH
FRP/PVC/PP

35

CHEMICAL
RESISTANCE OF
ASTRAL CHEMPRO

40

PARTIAL REFERENCE
LIST OF CLIENTS FOR
ASTRAL PIPING
SYSTEMS

1st TO
INTRODUCE
CPVC
IN INDIA

1st TO
INTRODUCE
UPVC LEAD
FREE PIPES
IN INDIA

1st TO
INTRODUCE
LOW NOISE
PP DRAINAGE
PIPES IN INDIA

1st TO
INTRODUCE
FOAMED PVC
DRAINAGE
PIPES IN INDIA



1st TO
INTRODUCE
LEAD FREE
COLUMN PIPES
IN INDIA

1st TO
INTRODUCE
POLYMER BASED
INDUSTRIAL
PIPING SYSTEM
IN INDIA

1st TO
INTRODUCE
NSF APPROVED
SOLVENT
CEMENT
IN INDIA

1st TO
INTRODUCE
CPVC PIPING FOR
AUTOMATIC
FIRE SPRINKLER
SYSTEM IN INDIA

ASTRAL, INDIA'S PROGRESSIVE BUILDING MATERIALS COMPANY

Established in 1996 with the aim to manufacture best-in-globe plastic piping systems, Astral Pipes fulfils emerging piping needs of millions of houses and adds extra mileage to India's developing real estate fraternity with the hallmark of unbeaten quality and innovative piping solutions. Keeping itself ahead of the technology curve, Astral has always been a front runner in the piping category by bringing innovation and getting rid of old, primitive and ineffective plumbing methods. Bringing CPVC in India, and pioneering in this technology, have set Astral apart and its highest quality enabled it to obtain NSF approval for its CPVC pipes and fittings. Astral went beyond the category codes by launching many industry firsts, like launching India's first lead-free uPVC pipes for plumbing as well as for stream water, just to name a few.

Astral Pipes offers the widest product range across this category when it comes to product applications. Astral Pipes is equipped with production facilities at Santej and Dholka in Gujarat, Hosur in Tamil Nadu, Ghiloth in Rajasthan, Sangli & Aurangabad in Maharashtra, and Sitarganj in Uttarakhand to manufacture plumbing systems, drainage systems, agriculture systems, fire sprinkler piping systems, industrial piping and electrical conduit pipes with all kinds of necessary fittings.

Astral Pipes' Infrastructure division offers a comprehensive product range including corrugated piping for drainage and cables, polyolefin cable channels, sewage treatment plants, plastic sheathing ducts, suction hoses, and sub-surface drainage systems. This range helps Astral to establish a strong foothold in infrastructure and agriculture sector in the constantly evolving business of piping.

In 2014, Astral forayed into the adhesives category by acquiring UK-based Seal It Services Ltd. and Kanpur based Resinova Chemie Ltd., which manufacture adhesives, sealants and construction chemicals. With five manufacturing facilities now in this business segment, Astral has strengthened its presence in the category and made rapid inroads.

In the year 2020, Astral has expanded its product portfolio and entered into the Water Tanks Segment. The water tank segment is an expanded domain of plumbing and water supply with a huge nationwide potential. Astral Pipes manufactures water tanks from its Santej, Aurangabad, Hosur & Ghiloth manufacturing facilities. A wide range of water storage tanks has helped Astral to become a versatile player in the industry.

Extending the product portfolio further, in the year 2022 Astral forayed into the categories of Faucets and Sanitaryware, followed by acquisition of Bangalore based Gem Paints to enter in the Paints category. This expansion will help Astral march firmly towards becoming a holistic building materials company.

ADHESIVES

EPOXY ADHESIVES & PUTTY
SILICONE SEALANTS
CONSTRUCTION CHEMICALS **PVA**
CYANOACRYLATE **SOLVENT CEMENTS**
TAPES **POLYMERIC FILLING COMPOUND**
ANAEROBIC ADHESIVES
INDUSTRIAL ADHESIVES
INSTANT HAND SANITIZER
SURFACE CLEANING PRODUCTS

PIPING

PLUMBING PIPES & FITTINGS
CPVC, PVC & PEX
SEWERAGE DRAINAGE PIPES & FITTINGS
AGRICULTURE PIPES & FITTINGS
INDUSTRIAL PIPES & FITTINGS
FIRE SPRINKLERS PIPES & FITTINGS
CONDUIT & CABLE PROTECTION
ANCILLARY PRODUCTS
URBAN INFRASTRUCTURE

WATER TANKS

PAINTS

DUCTING

FAUCETS

SANITARYWARE





INNOVATION & RECOGNITIONS

- First to introduce CPVC piping system in India (1999)
- First to launch lead free uPVC piping system in India (2004)
- Corp Excel- National SME Excellence Award (2006)
- First to get NSF Certification for CPVC piping system in India (2007)
- First to launch lead-free uPVC column pipes in India (2012)
- Enterprising Entrepreneur of the year (2012-13)
- Business Standard Star SME of the year (2013)
- Inc. India Innovative 100 for Smart Innovation under category of 'Technology' (2013)
- India's Most Promising Brand Award (2014)
- Value Creator Award during the first ever Fortune India Next 500 (2015)
- India's Most Trusted Pipe Brand Award (2016, 2019 & 2020)
- ET Inspiring Business Leaders of India Award (2016)
- India's Most Attractive Pipe Brand Award (2016)
- Fortune India 500 Company (2016)
- Consumer Validated Superbrands India (2017, 2019 & 2021)
- India's Most Desired Brand based on TRA's Brand Trust Report (2021)



MARKETING NETWORK

Astral has a marketing network of more than 800 distributors and 30,000 dealers spread all over India with branch offices at Mumbai, Pune, Delhi, Bengaluru, Chennai, Hyderabad, Jaipur, Lucknow and Kochi. Apart from that Astral has its own warehouses at Vijaywada, Hyderabad, Delhi, Kolhapur, Kolkata, Nagpur, Indore, Patna, Varanasi, Jaipur & Hosur to deliver the material as quick as possible. More than 400 techno marketing professionals and administrative personnel are on the board to coordinate with architects, plumbing contractors and plumbers to utilize the best plumbing techniques and to get the best from the products.

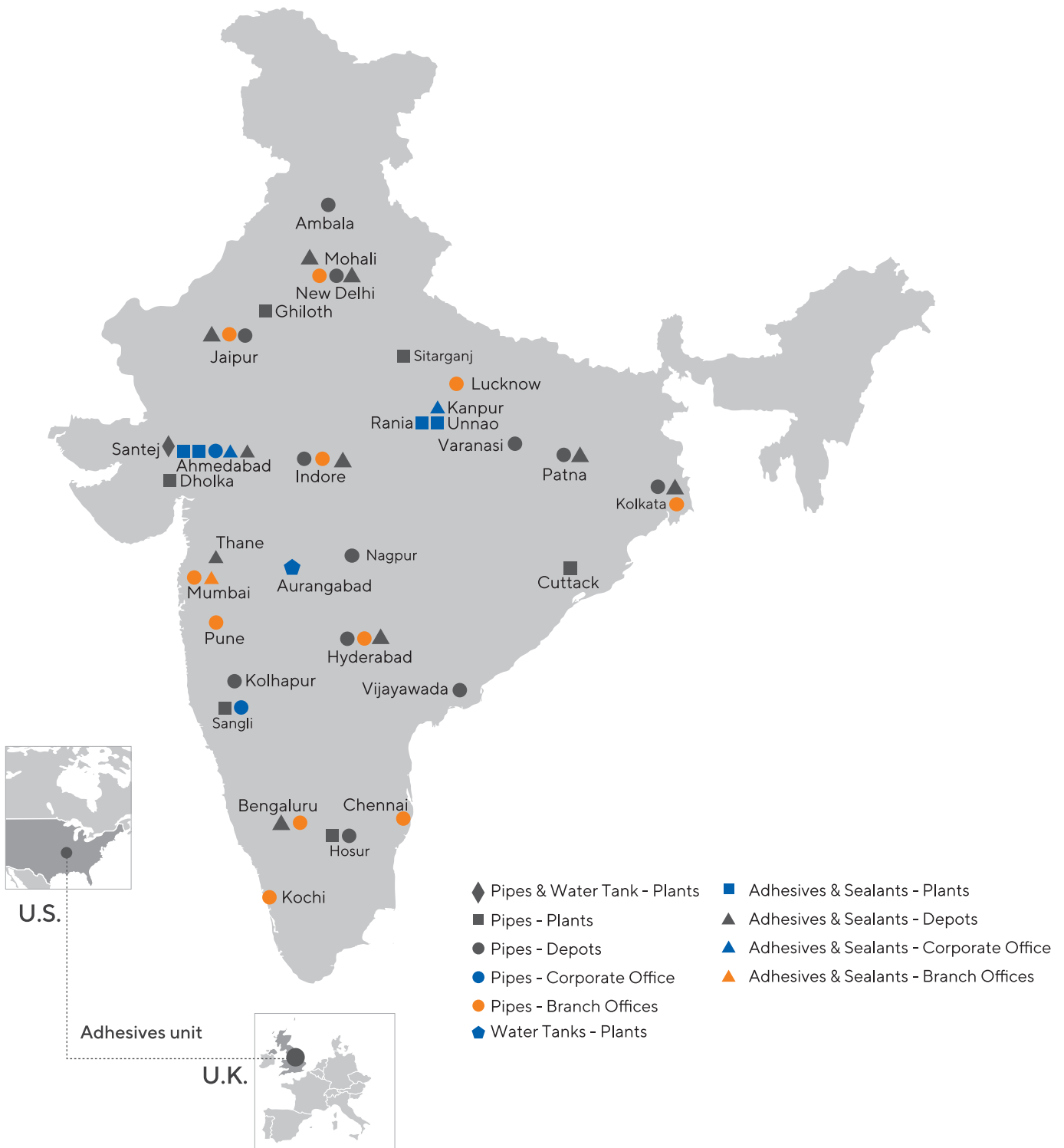

ABOUT CPVC

Chlorinated polyvinyl chloride (CPVC) has become an important thermoplastic due to its relative low cost, high glass transition temperature, high heat distortion temperature, chemical inertness & outstanding mechanical, dielectric, flame & smoke properties. CPVC is formulated by chlorination process of homopolymer PVC, brought an additional atom of chlorine (Cl) to the backbone of PVC. This will increase the base content of chlorine in PVC from 57% to 67-69% in industrial CPVC resin. As the chlorine content of CPVC increase the glass transition temperature (ts) of the polymer increases significantly. This will impart excellent mechanical, thermal as well as chemical resistance properties to CPVC. Since its inception in early 1960's CPVC has proven its value in variety of industrial application. This includes high temperature high pressure application with variety of chemicals.

ABOUT ASTRAL CHEMPRO

Astral ChemPro is proven CPVC piping system meeting all challenging application requirement of industrial piping system. It gives trouble free service to the industry for years together.

Astral ChemPro industrial piping system can be used upto 93°C temperature (Intermittent up to 110°C) & pressure based on the pipe sizes. Astral ChemPro CPVC industrial piping system is suitable for many industrial requirements like metal treating pump & raiser, Food & beverages, Industrial waste water, Chemical processing etc. Astral Limited is the only Indian company manufacturing industrial grade Chlorinated Polyvinyl Chloride (CPVC) Pipes of schedule 40 & 80 and fittings of schedule 80 conform to ASTM Standards ranging from ½"(15mm) to 12" (300mm). All Astral ChemPro CPVC industrial pipes are produced from compound confirming to ASTM D1784.

Many chemicals encountered in the process industry aggressively corrode most metal equipment resulting in process leaks, flow restrictions and ultimately premature failure. In addition to metals there are other thermoplastics used in industry which get affected by these aggressive chemicals at elevated temperatures and pressures and lead to premature failure. Long Service life, minimum downtime and environmental compliance are critical to the success and growth of firms in the process industry. A challenging effort is required for the industry to achieve the successes where corrosion can decrease piping life, interrupt production and create potential environmental hazards. As a result, these industries often require process-piping systems those are made of materials that can withstand tough industrial environments. Ideally, this means a cost effective material that will resist corrosion eventually providing mechanical strength, safety and long lasting performance.

WHY ASTRAL CHEMPRO

- Astral is pioneer in CPVC piping industry having more than 17 years of expertise in CPVC piping system in india.
- One of the most advanced CPVC industrial piping systems available globally.
- The Compound meets or exceeds the requirement of cell class 24448 against the standard cell class 23447
- Complete product range from ½” (15mm) to 12” (300mm) with wide range of fittings
- Provides special nonmetallic valves like Ball valve, Butterfly valve, Diaphragm valve, Non return valve. Available both in manual & actuated operational.
- Astral imparts complete knowledge of CPVC piping system including training, installation & after sales service support.
- Dedicated sales-force on industrial systems.

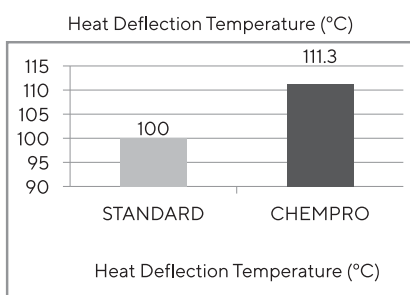
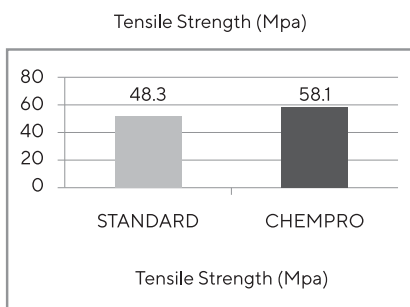
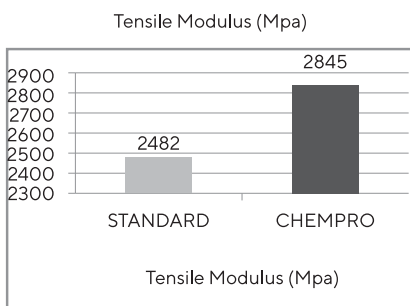
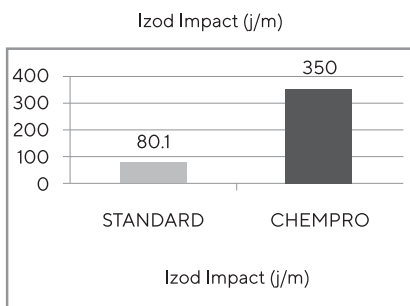

CIPA / QF / 5.10.1

सेन्ट्रल इंस्टिट्यूट ऑफ प्लास्टिक्स इंजीनियरिंग एण्ड टेक्नोलॉजी
(संयोजन एवं जलसंधि विभाग, भारत सरकार)
630, प्लॉट 4, जीआईडीसी, वडवा, अहमदाबाद - 382 445.
दूरभाष : 079-40103900 / 40103923 फेक्स : 40083905
Email : cipetahmd@gmail.com / ahmedabad@cipet.gov.in
Website : www.cipet.gov.in

CENTRAL INSTITUTE OF PLASTICS ENGINEERING AND TECHNOLOGY
(Ministry of Chemicals & Fertilizers, Govt. of India)
630, Pl. IV, GIDC, Vahva, Ahmedabad - 382 445
Ph: 079-40103900 / 40103923 Fax: 40083905
Email : cipetahmd@gmail.com / ahmedabad@cipet.gov.in
Website : www.cipet.gov.in

PLASTICS TESTING CENTRE

CPVC Chempro Compound- Compression Moulded Sheet
Size : 200mm x 200mm, ASTRAL CHEMPRO COMPOUND

Test Report No.: 3796
Dated : 18.11.2016

**PART C
TEST RESULTS**

Sr. No.	Clause	Test	Test Method	Unit	Result Obtained
1	11.3	Tensile Strength at Break	ASTM D 638	Mpa	58.1
2	11.3	Modulus of Elasticity		Mpa	2845
3	11.4	Izod Impact	ASTM D 256	J/m	350
4	11.5	Heat Deflection Temperature @ 1.82 Mpa	ASTM D 648	°C	111.3
5	11.6	Flammability	ASTM D 635		
		Average Time of Burning		Sec.	3
		Average Extent of Burning		mm	5

PART D

REMARKS : NIL
NOTE : 1 The results related only to the items tested
2 The report shall not be reproduced in full/part without written approval of the laboratory

[Signature]
Authorised Signatory

[Signature]
Authorised Signatory
2 of 2

01-10000/F-1.4.16/C.G. Head Office : CIPET, Guindy, Chennai - 600 032

ADVANTAGES



HIGH TEMPERATURE RESISTANCE

Astral ChemPro CPVC piping system can be used upto service temperature of 93°C (200°F). Also it can be used at temperature of 110°C (Intermittent).



EXTERNAL CORROSION RESISTANCE

Industrial fumes, humidity, salt water weather condition, regardless of type of soil or moisture encountered, can't harm Astral ChemPro CPVC Pipes. Scratches of abrasion do not provide point which corrosive elements can attack.



EASY INSTALLATION AND LOW INSTALLATION COST

Astral ChemPro CPVC pipes are light in weight. They have smooth, seamless interior walls. No special tools are required for cutting. These features lead to lower installation cost than conventional metal piping. Solvent Cemented Connections Contributes to this lower installation cost while much lighter weight (about one sixth as much as steel) speeds and simplifies handling during installation.



IMMUNITY TO GALVANIC OR ELECTROLYTIC ATTACK

Astral ChemPro CPVC pipe is inherently immune to galvanic or electrolytic action. They can be used underground. Underwater, in the presence of metals and can be connected to other materials, or used as and insulator between them.



CHEMICAL RESISTANCE

Astral ChemPro CPVC pipe is inactive to attack by strong acids, alkalis, self solution, alcohols etc. Dependable in corrosive application & impart no tasters or odours to materials carried in it. It does not react with materials carried, nor as a catalyst. All possibility of contamination, or chemical process changes, and all dangers of clouding slugging or discolouration are eliminated.



FREEDOM FROM TOXICITY, ODOURS, TASTES

Astral ChemPro CPVC piping is non-toxic, odourless and tasteless.



CORROSION FREE

While in many other pipe materials, corrosion may occur and the corroded particles can contaminate the piped fluid, complicating further processing or causing bad taste, odours or discolouration. This is particularly undesirable when the piped fluid is for domestic consumption. With Astral ChemPro CPVC there are no corrosive by products, therefore no contamination of the piped fluid.



LOW THERMAL CONDUCTIVITY

Astral ChemPro CPVC Pipe has a much lower thermal conductivity factor than metal pipe. Therefore, fluids being piped maintain more constant temperature. In most cases, pipe insulation is not required. However, applying insulation can lead to have more energy saving & temperature loss.



LOW FRICTION LOSS

The smooth inner surface of Astral ChemPro CPVC Pipe compared to metal and other piping materials, assure, low friction and high flow rates. Additionally, since Astral ChemPro CPVC Pipe will not rust, pit, scale or corrode, the high flow rates will be maintained for the life of the piping system.



MAINTENANCE FREE

Once Astral ChemPro CPVC Piping system is properly selected, designed, and installed, it is virtually maintenance free. It will not rust, scale, pit, corrode or promote build-up on the interior, Therefore years of trouble free service can be expected when using Astral ChemPro CPVC pipes, fitting and valves.



UV STABILIZED

Astral ChemPro CPVC Industrial Piping System can be used in sunlight exposed conditions.

GENERAL SPECIFICATIONS

PRODUCT DESCRIPTION

Astral ChemPro CPVC Industrial Systems are produced from specialty plastic compounds known as post-chlorinated polyvinyl chloride (CPVC). The compound meets cell class 24448 as defined by ASTM D1784 and have a design stress of 2000 psi and a maximum service temperature of 93°C.

Pipe: Pipe shall meet or exceed the requirements of ASTM F441 in Schedule 40 and 80 dimensions. Available in size range 15mm (½") to 300 mm (12").

Fittings: Fittings shall meet or exceed the requirements of ASTM F437 (Schedule 80 threaded) or ASTM F439 (Schedule 80 socket). Available in size range ½" to 12".

Primer/Solvent Cement: All socket type joints shall be made up employing primer and solvent cements that meet or exceed the requirements of ASTM F656 and ASTM F493. Both primer and solvent cement shall confirm with the requirements of NSF Standard 14. Only CPVC solvent cement and primer shall be used when making CPVC solvent cement joints.

Marking and Uniformity: Pipe and fittings made from Astral ChemPro CPVC compounds shall be clearly marked with the manufacturer's name or trademark, material designation applicable ASTM Standard.

APPLICABLE STANDARDS

- ASTM D1784 - Standard Specification for Rigid Polyvinyl Chloride (PVC) and Chlorinated Polyvinyl Chloride (CPVC) Compounds.
- ASTM F441 - Standard Specification for Chlorinated Polyvinyl Chloride (CPVC) Plastic Pipe, Schedules 40 and 80.
- ASTM F437 - Standard Specification for Threaded Chlorinated Polyvinyl Chloride (CPVC) Plastic Pipe Fittings, Schedule 80.
- ASTM F439 - Standard Specification for Socket-Type Chlorinated Polyvinyl Chloride Plastic Pipe Fittings, Schedule 80.
- ASTM F402 - Standard Practice for Safe Handling of Solvent Cement and Primer Used for Joining Thermoplastic Pipe and Fittings.
- ASTM F493 - Standard Specification for solvent Cements for Chlorinated Polyvinyl Chloride (CPVC) Plastic Pipe and Fittings.
- ASTM F656 - Standard Specification for Primers Used in Solvent Cement Joints of Polyvinyl Chloride (PVC) Plastic Pipe and Fittings

BASIC USE

Astral ChemPro CPVC pipe and fittings are intended for use in both pressure and drain applications in general chemical manufacturing plants, pulp and paper plants, waste water treatment plants, metal treating/electroplating plants, water purification plants, and food processing plants where excellent resistance to corrosion from a wide range of chemicals, acids, and bases at temperatures up to 93°C is required.

SYSTEM DESIGN

System design shall be in accordance with standard industry practice for thermoplastic industrial piping systems and shall take into consideration such factors as pressure and flow requirements, friction loss, operating temperatures, support spacing, anchoring, bracing and thrust blocking, temperature correction factors, joining methods, chemical environment, collapse and loading, and thermal expansion and contraction.

WELD LINE IN MOLDED FITTINGS

A knit line is the line where two resin flows meet while product is manufactured by Injection moulding process.

The injection molding is the most commonly used manufacturing process which forces the molten plastic material into this interstitial space. A knit line in a plastic injection-molded part is created when two separate plastic flows forced into a closed mold that defines the shape of the article along their interface. There the material is cooled until it reverts to a solid, then the mold is opened and the finished part is extracted. Inherent in this process, for most geometries, is the flowing together of the material and the development of a weld line.

The spot where the plastic material is forced into the mold is denominated as the gate. The molten plastic material flows through this gate, and when it hits the core it will flow around it in both directions. At the point where the material flows back together there will usually be a line, termed a weld line or a knit line. This point of the material flowing back together is usually located about 180° from the gate and, since the weld line is visible on both the OD and ID. Depending on the resin, resin temperature, mold temperature, and filling speed, knit lines can vary from virtually invisible to something that looks like cracks in the plastic.

Although this weld line (knit line) is only the superficial appearance and it does not have any indicate imperfection or fragility. Astral Fittings undergoes to some significant pressure tests, according to the ASTM Specifications to provide the best quality molded component

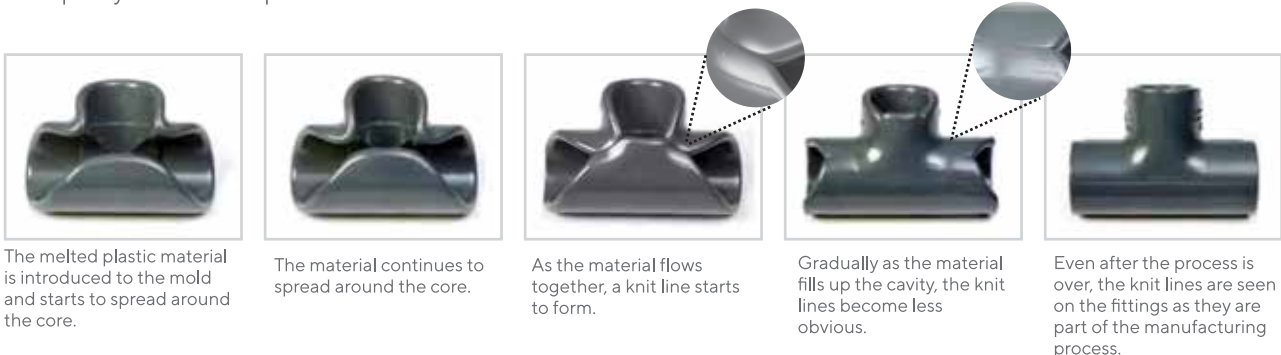

CAUTIONS/ LIMITATIONS

- Air or compressed gas shall never be used for pressure testing rigid thermoplastic piping systems.
- Temperature correction factors shall be applied when operating temperatures exceed 23°C.
- Only Schedule 80 pipe may be threaded up to and including 4" size, and threads shall be in accordance with ANSI B1.20.1 Taper pipe Thread.
- Only water soluble oil or water shall be used when threading CHEMPRO pipe.
- Only Teflon tape shall be used when making plast connections.
- Flanged systems shall not exceed 150 psi working pressure.
- Threaded joints shall have 50% of the pressure rating of Schedule 80 pipe.
- Astral ChemPro CPVC is not recommended for use with most polar organic solvents such as chlorinated or aromatic hydrocarbons, esters, or ketones. Prior testing is recommended when required service includes surfactant, oil, or grease. Consult Astral for specific chemical resistance information.
- System should not be operated or flushed out at flow velocity greater than 5 feet per second.

THE IDEAL CHOICE FOR

METAL TREATING:

Many different metal treatment methods and the wide selection of metals involved require the use of very aggressive acids and alkalis at high temperatures and pressure. High concentrations of chromic acid and sulfuric acid are common in the industry where temperature sometimes reach upto 93°C (200°F). Whether it is etching, anodizing, pickling, or plating, the properties of the Astral ChemPro CPVC Industrial Piping System in these processes make it the ideal choice in the industry.

PULP AND PAPER:

Pulp mills use a variety of corrosive chemicals in the bleaching and pulp processing steps. Chemicals such as chlorine dioxide, sodium hypochlorite, sulfuric acid, and the various pulp liquors generally attack carbon and stainless steels, significantly limiting service life. With many mills beginning to focus more on cost competitiveness, the life-cycle cost benefits of Astral ChemPro CPVC Industrial Piping System is well suited to meet the Demands of the industry.

FOOD AND BEVERAGE INDUSTRY:

Many food and beverage plants require meticulous cleaning in order to meet health standards. To properly clean the processing equipment, high temperature water and harsh chemicals or cleaning agents are often necessary. These conditions can corrode most metals, and many polymers will not withstand the temperature extremes. Astral ChemPro CPVC Industrial Piping System will perform well in such situations and is an economical alternative to various conventional piping systems.

INDUSTRIAL WASTE TREATMENT:

Most industrial waste streams consist of corrosive chemicals that can vary widely in concentration and temperature. Here, the versatility of Astral ChemPro CPVC Industrial Piping System is ideally suited to prove reliable operation in a variety of process conditions. With the environmental regulations on industrial waste handling becoming more stringent, the Astral ChemPro CPVC Industrial System offers a cost-effective solution to help ensure environmental compliance.

CHEMICAL PROCESSING:

The chemical processing industry includes a wide range of applications, many of which require excellent corrosion resistance, at higher temperature and pressure with mechanical strength. Astral ChemPro CPVC Industrial Piping System can be specified when outstanding performance is required, particularly when acids and alkalis are encountered. This versatility and availability of the full range of Astral ChemPro CPVC Pipes, fittings, and valves help excellent material performance throughout the entire system.

HVAC (HEATING, VENTILATION & AIR CONDITIONING) APPLICATION:

Our Chempro CPVC Industrial Piping system is ideal for HVAC (Heating, Ventilation & Air Conditioning) and chilled water application where in the water temperature should be min. 5°C. We recommend XLPE insulation Insupro to prevent possible condensation.

BASIC PHYSICAL PROPERTIES

PROPERTY	TEST	CONDITION	ENGLISH UNIT	SI UNITS
GENERAL				
Specific Gravity	ASTM D792	73°F/23°C	1.52 g/cm ³	1.52 g/cm ³
Specific Volume		73°F/23°C	.0105 ft ³ /lb	0.657 cm ³ /g
Water Absorption	ASTM D570	73°F/23°C	0.03%	0.03%
		212°F/100°C	0.55%	0.55%
Rockwell Hardness	ASTM D785	73°F/23°C	116	
Cell Class	ASTM D1784		24448-B	
MECHANICAL				
Izod Impact	ASTM D256	73°F/23°C	5.06 ft lbs/in o.n.	270 J/m o.n.
Tensile Strength	ASTM D638	73°F/23°C	8200 psi	56 N/mm ²
Tensile Modulus	ASTM D638	73°F/23°C	384, 000 psi	2650 N/mm ²
Flexural Strength	ASTM D790	73°F/23°C	15,400 psi	106 N/mm ²
Flexural Modulus	ASTM D790	73°F/23°C	419,000 psi	2890 N/mm ²
Compressive Strength	ASTM D695	73°F/23°C	10,600 psi	73 N/mm ²
Compressive Modulus	ASTM D695	73°F/23°C	198,000 psi	1365 N/mm ²
THERMAL				
Coefficient of Thermal Expansion	ASTM D696		3.4x10 ⁻⁵ in/in/°F	6.3x10 ⁻⁵ m/m/K
Thermal Conductivity	ASTM C177		0.95 BTU in/hr/ft ² /°F	0.137 W/m/K
Heat Distortion Temperature@264psi	ASTM D648		232°F	111°C
*Heat Capacity	DSC	73°F/23°C	0.21 BTU/lb °F	0.90 J/gK
		212°F/100°C	0.26 BTU/lb °F	1.10 J/gK
FLAMMABILITY				
Flammability Rating	UL94	0.062 in/0.157 cm	V-O, 5VB, 5VA	
Flame Spread	ASTM E84		15	
Smoke Developed	ASTM E84		70-125	
Limiting Oxygen Index	ASTM D2863		60%	
ELECTRICAL				
Dielectric Strength	ASTM D147		1250 V/mil	492,000 V/cm
Dielectric Constant	ASTM D150	60 Hz, 30°F/-1°C	3.7	3.7
Power Factor	ASTM D150	1000 Hz	0.01%	0.01%
Volume Resistivity	ASTM D257	73°F/23°C	3.4x10 ¹⁵ ohm/cm	3.4x10 ¹⁵ ohm/cm

DIMENSIONS

ASTRAL CHEMPRO CPVC PIPE DIMENSIONS SCH 40

Nominal Pipe Size		Outside Diameter		Average Inside Diameter		Minimum Wall thickness		Maximum Water Pressure	
in	mm	in	mm	in	mm	in	mm	KG/CM ² @23°C	(PSI) @73°F
½	15	0.840	21.34	0.608	15.44	0.109	2.77	42.18	600
¾	20	1.050	26.67	0.810	20.57	0.113	2.87	33.75	480
1	25	1.315	33.40	1.033	26.24	0.133	3.38	31.64	450
1¼	32	1.660	42.16	1.364	34.65	0.140	3.56	26.01	370
1½	40	1.900	48.26	1.592	40.44	0.145	3.68	23.20	330
2	50	2.375	60.33	2.049	52.04	0.154	3.91	19.69	280
2½	65	2.876	73.03	2.445	62.10	0.203	5.16	21.09	300
3	80	3.500	88.90	3.042	77.27	0.216	5.49	18.28	260
4	100	4.500	114.30	3.998	101.55	0.237	6.02	15.47	220
5	125	5.563	141.30	5.010	127.42	0.258	6.55	13.35	190
6	150	6.625	168.28	6.031	153.19	0.280	7.11	12.66	180
8	200	8.625	219.08	7.943	201.75	0.322	8.18	11.25	160
10	250	10.750	273.05	9.976	253.39	0.365	9.27	9.84	140
12	300	12.750	323.85	11.890	302.01	0.406	10.31	9.14	130

Mpa = Mega Pascal 1 Mpa = 10.19 kg/cm² 1 kg/cm² = 14.2233343 PSI.

*Pressure rating applies for water at 23°C. For temperatures greater than 23°C see derating factors. For fluids other than water the full pressure rating may not apply; see chemical resistance table.

**Schedule 40 pipe or Schedule 80 pipe 6" or larger should never be threaded. Schedule 80 pipe operating above 65°C should not be threaded. Use flanged joints, unions, or victaulic couplings where occasional disassembly is necessary.



ASTRAL CHEMPRO CPVC PIPE DIMENSIONS SCH 80

Nominal Pipe Size		Outside Diameter		Average Inside Diameter		Minimum Wall thickness		Maximum Water Pressure	
in	mm	in	mm	in	mm	in	mm	KG/CM ² @23°C	(PSI) @73°F
½	15	0.840	21.34	0.528	13.14	0.147	3.73	59.76	850
¾	20	1.050	26.67	0.724	18.39	0.154	3.91	48.51	690
1	25	1.315	33.40	0.935	23.75	0.179	4.55	44.29	630
1¼	32	1.660	42.16	1.256	31.90	0.191	4.85	36.56	520
1½	40	1.900	48.26	1.476	37.49	0.200	5.08	33.04	470
2	50	2.375	60.33	1.913	48.59	0.218	5.54	28.12	400
2½	65	2.876	73.03	2.289	58.14	0.276	7.01	29.53	420
3	80	3.500	88.90	2.864	72.75	0.300	7.62	26.01	370
4	100	4.500	114.30	3.786	96.16	0.337	8.56	22.50	320
5	125	5.563	141.30	4.768	121.12	0.375	9.52	20.38	290
6	150	6.625	168.28	5.709	145.01	0.432	10.97	19.69	280
8	200	8.625	219.08	7.565	192.15	0.500	12.70	17.58	250
10	250	10.750	273.05	9.492	241.10	0.593	15.06	16.17	230
12	300	12.750	323.85	11.294	286.87	0.687	17.45	16.17	230

Mpa = Mega Pascal 1 Mpa = 10.19 kg/cm² 1 kg/cm² = 14.2233343 PSI.

TEMPERATURE DERATING FACTOR - PIPES

Working Temperature (°F)	78-80	90	100	120	140	160	180	200
Working Temperature (°C)	23-25	32	38	49	60	71	82	93
Pipe Derating Factor	1.00	0.91	0.82	0.65	0.50	0.40	0.25	0.20

PRESSURE RATINGS FOR CPVC VALVES

CPVC valves will typically be rated to either 150 psi or 225 psi at 23°C. Derating factors for higher temperatures are shown here. Contact Astral for specific information on CPVC valves. Pressure Ratings for Flanged Systems Flanged systems of any size should not exceed 150 psi working pressure.

Pressure Ratings for Threaded Systems Threaded systems are derated to 50% of the pressure rating for the piping at the system operating temperature.

CPVC SCH 40 & SCH 80 PIPES & FITTINGS



SCH-40



SCH-80



TEE (SOC)



REDUCERTEE (SOC)

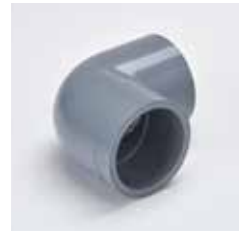

90° ELBOW - SOC



CROSS (SOC)



REDUCER COUPLING (SOC)

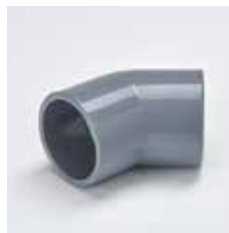

ELBOW 45° (SOC)



COUPLER (FAPT)



MAPT (PVC THREAD)



COUPLER (SOC)



CAP (SOC)



FLANGE HUB SOC



CLAMP SADDLE



REDUCER BUSHING (SPIG x SOC)



UNION



BUTTERFLY VALVE VITON W/HANDLE



DIAPHRAGM VALVE FLANGED EPDM



BALL VALVE

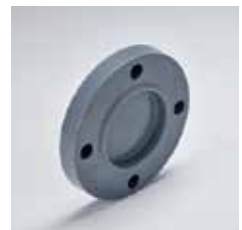

BLIND FLANGE



VANSTONE FLANGE (SOC)



FLANGE - SPIG



P-70 PRIMER

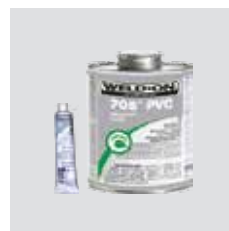

705 PVC

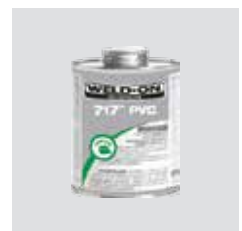

717 PVC

COMPREHENSIVE VALVE RANGE

INDUSTRIAL BALL VALVE

- Multi-featured Industrial Grade
- Built-in Handle Lockout
- Fully Serviceable, Replaceable Components
- Safe-T-Blocked® Seal Carrier - Full Rated Pressure
- ISO Pattern Actuation Mounting Option
- Spears® Dual O-ring Safe-T-Shear® Stem
- Self Adjusting PTFE Floating Seat Design
- Sizes 1/2" - 4" pressure rated to 235 psi @ 23°C, Sizes 6" - 8" and all flanged to 150 psi @ 23°C
- EPDM NSF Certified for Potable Water Use
- Produced in IPS sizes 1/2" - 6" with Socket, Threaded, Flanged, Spigot or SR Threaded End Connectors



INDUSTRIAL GATE VALVE

- Heavy Bodied CPVC
- Non-rising Stem
- Buna-N, EPDM or FKM O-rings.
- Specially Designed Sealing Surface
- Size range 1/2" through 2", 2-1/2" & 3" and in the full featured Heavy Industrial 4" valve
- NSF® Certified for potable water service



INDUSTRIAL BALL CHECK VALVE

- Industrial Grade
- Flow-Tested for Minimum Turbulence
- Fully Serviceable, Replaceable Components, uses Standard O-ring Seat
- Safe-T-Blocked® Seal Carrier - Full Rated Pressure
- Easily Converted to Foot Valve
- EPDM NSF Certified for Potable Water Use
- Sizes 1/2" - 4" pressure rated to 235 psi @ 23°C, Sizes 6" - 8" and all flanged to 150 psi @ 23°C
- Produced in IPS sizes 1/2" - 6" with Socket, Threaded, Flanged, Spigot or optional SR Threaded End Connectors
- Produced in size 8" with Socket and Flanged End Connectors



All valves/strainers are SPEARS make

COMPREHENSIVE VALVE RANGE

INDUSTRIAL DIAPHRAGM VALVE

- Heavy Bodied Schedule 80 CPVC Construction with Mountable Body
- Choice of Chemical/Abrasion Resistant Elastomeric or PTFE Diaphragms
- PVC & CPVC 1/2" - 2" valves with Flanged Body, Spigot Body or True Union style Socket & Thread ends or Optional Special Reinforced (SR) Threads, and sizes 2-1/2" - 8" with Flanged Body
- Polypropylene 1/2" - 2" valves with True Union style Special Reinforced (SR) Threaded ends and sizes 2-1/2" - 8" with Flanged Body
- Buna-N, EPDM or FKM O-rings



BUTTERFLY VALVE

- Special off-set Disc lifts quickly from seat to reduce wear and
- Interlocking Body & Seat prevents wash-out or blow-out.
- Buna-N, EPDM or FKM Seat & Seals
- Fully Isolated Solid Type 316L Stainless Steel Stem
- Reversible High Impact Polypropylene Lever Handle with 7-Position stops & Built-in Lockout (standard handle on 1-1/2" - 8" valves; not available on 10" & larger valves)
- Pressure Rated to 150 psi @ 23°C including Dead-End Service.
- ANSI/ASME B16.5 Class 150 Bolt Pattern
- Valves with EPDM Seals & Seats are NSF® Certified for Potable water use.



NEEDLE VALVE

- Chemical & Corrosion Resistant CPVC Construction
- Precision Metering Chamber
- Globe & Angle Body Configurations
- Removable Bonnet For Easy Disassembly & Cleaning
- Solid PTFE Stem Seal - No Elastomer Seal or Lubricants Used
- Built-in Panel or Bracket Mounting Nut
- Easy-Grip Polypropylene Handle
- PVC & CPVC Pressure Rated to 235 psi @ 23°C, Polypropylene Pressure Rated to 150 psi @ 23°C



All valves/strainers are SPEARS make

INDUSTRIAL Y - STRAINERS VALVE

- Provides In-line Protection of Process Equipment
- CPVC Clear Construction
- EPDM or FKM O-ring Seals
- Removable Strainer Basket with O-ring Sealed Drain Plug
- Allows Quick-Flushing or Bleed-Off Valve Connection
- Multiple Strainer Screen Options in CPVC Type 316 Stainless Steel (see Mesh Code table)
- Optional Magnetic Drain Plug for Ferrous Metal Pickup
- Suitable for Horizontal or Vertical Installation
- Sizes 1/2"- 2" Pressure Rated to 150 psi @ 23°C
Sizes 3"- 4" to 90 psi @ 23°C
- Assembled with Silicone-Free, Water Soluble Lubricants



INDUSTRIAL BUTTERFLY CHECK VALVES

- Chemical Resistant CPVC Construction
- No Metal Components
- Quick Response Shut-off In any Position
- Replaceable Internal Components - Choice of Reinforced EPDM or FKM
- Suitable for Horizontal or Vertical Installation
- Sizes 2" - 8" Pressure Rated to 150 psi for water at 23°C,
Sizes 10" - 16" Pressure Rated to 100 psi for water at 23°C,
Sizes 18" - 24" Pressure Rated to 50 psi for water at 23°C
- Assembled with Silicone-Free, Water Soluble Lubricants

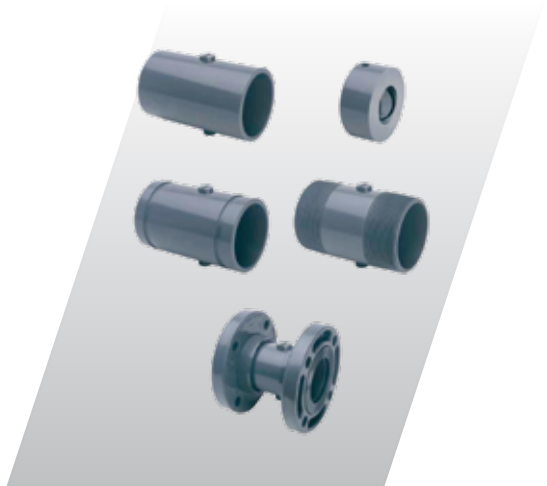

All valves/strainers are SPEARS make

THERMAL EXPANSION AND CONTRACTION

Like all piping material, Astral ChemPro expands when heated and contracts when cooled. ChemPro piping (regardless of pipe diameter) will expand about 1 inch per 50 feet of length when subjected to a 50° F temperature increase, therefore, allowances must be made for this resulting movement. However, laboratory testing and installation experience have demonstrated that the practical issues are much smaller than the coefficient of thermal expansion would suggest. The stresses developed in ChemPro pipe are generally much smaller than those developed in metal pipe for equal temperature changes because of the difference in elastic modulus. Required loops are smaller than those recommended by the Copper Development Association for copper systems. Expansion is mainly a concern in hot water lines. Generally, thermal expansion can be accommodated with changes in direction.

However, a long straight run may require an offset or loop. Only one expansion loop, properly sized is required in any single straight run, regardless of its total length. If more convenient, two or more smaller expansion loops, properly sized, can be utilized in a single run of pipe to accommodate the thermal movement. Be sure to hang pipe with smooth straps that will not restrict movement.

For convenience, loop (or offset) length have been calculated for different pipe sizes and different run length with a temperature increase (DT) of about 80°F. The results, shown in Tables A and B, are presented simply as a handy guide for quick and easy determinations of acceptable loop length for the approximate conditions. Loop length for other temperatures and run length can be calculated utilizing the following equations :

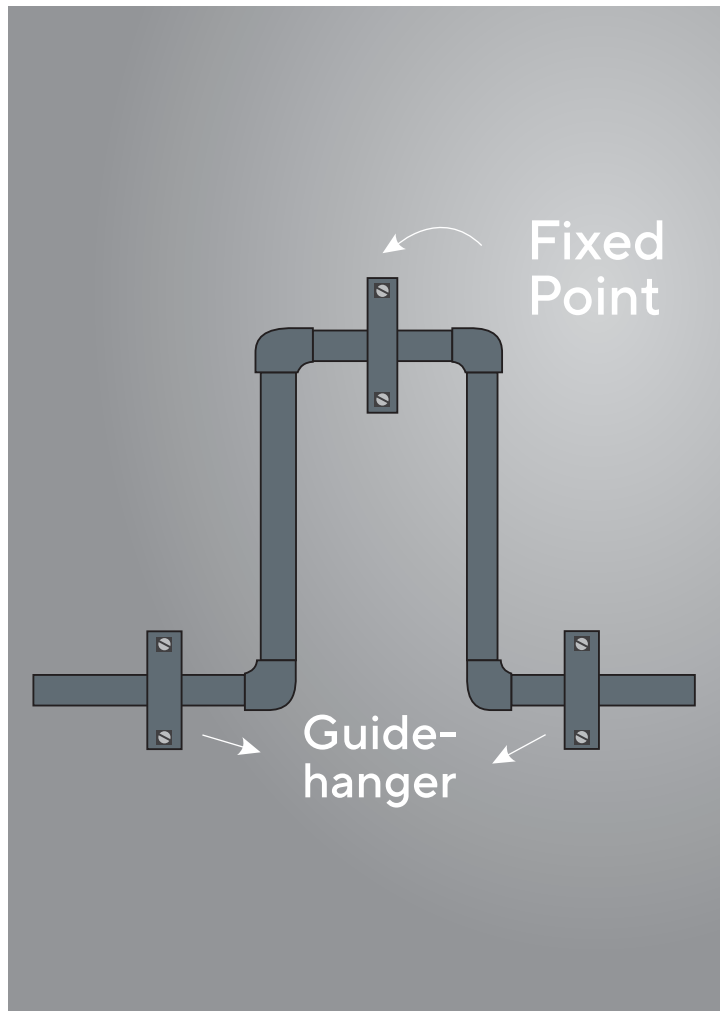

EXPANSION LOOP FORMULA

$$L = \sqrt{\frac{3ED(\Delta L)}{2S}}$$

Where:

- L = Loop Length (in.)
- E = Modulus of elasticity at maximum temperature (psi)
- S = Working stress at maximum temperature (psi)
- D = Outside diameter of pipe (in.)
- ΔL = Change in length due to change in temperature (in.)

THERMAL EXPANSION FORMULA

$$\Delta L = L_p C \Delta T$$

Where:

- ΔL = Change in length due to change temperature (in.)
- L_p = Length of pipe (in.)
- C = Coefficient of thermal expansion (in./ in./°F)
= 3.4×10^{-5} in./ in./°F for ChemPro
- ΔT = Change in temperature (°F)

THERMAL EXPANSION AND CONTRACTION

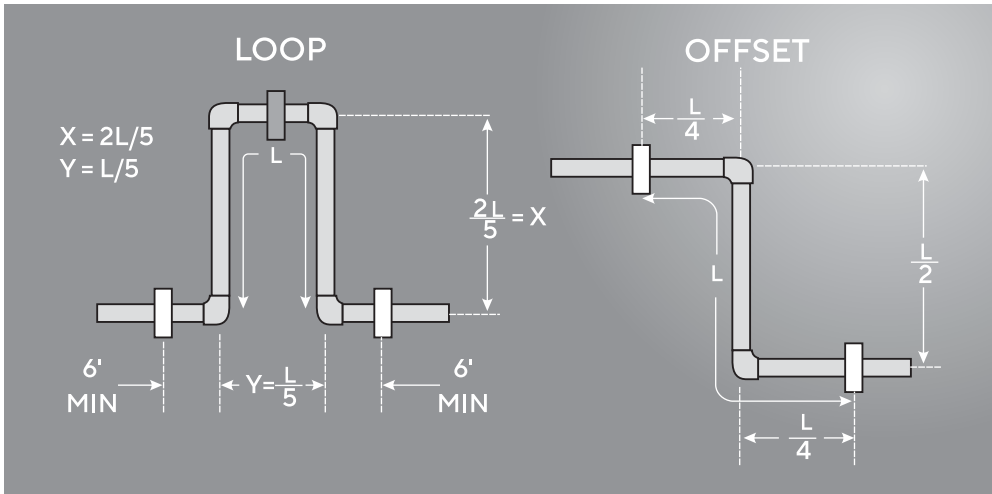

Modulus of Elasticity and Working Stress For CPVC

Temperature		Modulus, E(ksi)	Stress, S(ksi)
°F	°C		
73	(27)	423,000	2000
90	(32)	403,000	1800
110	(43)	371,000	1500
120	(49)	355,000	1300
140	(60)	323,000	1000
160	(71)	291,000	750
180	(82)	269,000	500

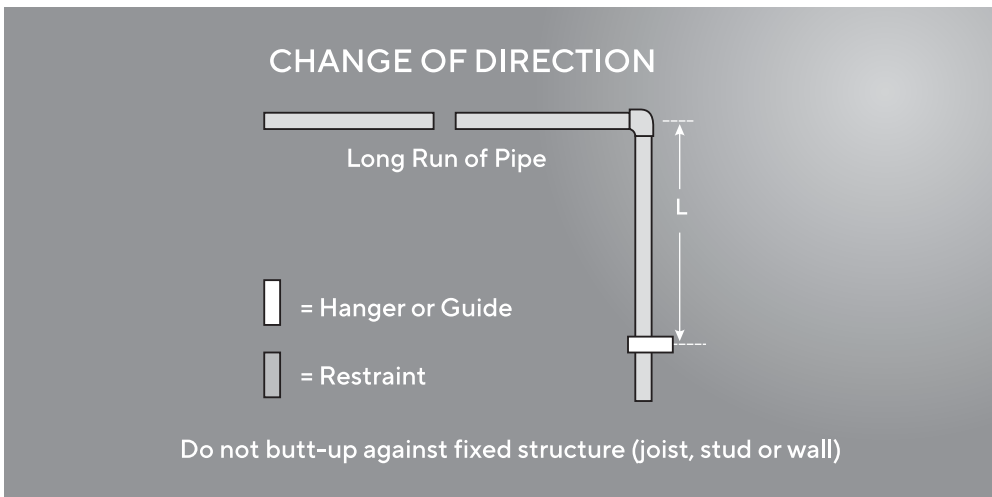

INSTALLATION PROCEDURE

BASIC PRINCIPLES OF SOLVENT CEMENTING

To make consistently good joints, the following points should be clearly understood.

- 1. Cut Pipe Square :** Always use the proper tools for cutting CPVC Pipe, such as a Saw & Miter Box, Wheel cutter or a Pipe Cutter. These tools ensure a square (90°) cut.
- 2. Remove Burr and Bevel outside rim :** Deburr with a knife or De-Burring tool and bevel edges to 10°- 15° so the pipe will fit closely into socket.
- 3. Clean Pipe and Fittings :** Wipe off all joining surfaces with a clean, dry rag. Dust, Dirt, Grease (even fingerprints) and Moisture can interfere with the penetration and bonding properties of primer and solvent cement.
- 4. Apply primer (for 2-½" & Above) :** Apply primer to pipes and fitting with a sequence of Fitting Pipe Fitting.
- 5. Apply Solvent Cement :** Apply solvent cement to pipes and fittings with a sequence of Pipe Fitting Pipe.
- 6. Work quickly :** Immediately after applying solvent cement insert pipe into fitting. Assemble immediately solvent quickly evaporate. While cement is still wet, Push and Twist (¼ Turn) socket on to pipe Until it bottoms out and hold parts together for about 30 seconds to avoid push-out. Keep pressure on pipe and fitting until cement sets.
- 7. Remove excess cement :** Remove excess cement from joints by clean cloth. If left on exposed pipe, the softening effect of excess solvent could permanently distort or weaken pipe.

Penetration and softening can be achieved by the cement itself, by using a suitable primer or by the use of both primer and cement. For certain materials and in certain situations, it is necessary to use a primer. A suitable primer will usually penetrate and soften the surfaces more quickly than cement alone. Additionally, the use of a primer can provide a safety factor for the installer, for he can know under various temperature conditions when sufficient softening has been achieved. For example, in cold weather more time and additional applications may be required.

Sufficient cement to fill the loose part of the joint must be applied. Besides filling the gap, adequate cement layers will penetrate the surfaces and also remain wet until the joint is assembled. Prove this for yourself. Apply on the top surface of a piece of pipe two separate layers of cement.

First apply a heavy layer of cement; then along side it, apply a thin brushed out layer. Test the layers every 15 seconds or so by a gentle tap with your finger. You will note that the thin layer becomes tacky and then dries quickly (Probably within 15 seconds); the heavy layer will remain wet much longer. A few minutes after applying these layers check for penetration. Scrape the surface of both with a knife. The thin layer will have achieved little or no penetration; the heavy one will have achieved much more penetration.

If the cement coatings on the pipe and fittings are wet and fluid when assembly takes place, they will tend to flow together and become one cement layer. Also, if the cement is wet, the surfaces beneath them will still be soft and these softened surfaces in the tight part of the joint will tend to fuse together. As the solvent dissipates, the cement layer and the softened surfaces will harden with a corresponding increase in joint strength. A good joint will take the required working pressure long before the joint is fully dry and final joint strength is obtained. In the tight (fused) part of the joint, strength will develop more quickly than in the looser (bonded) part of the joint.



SOLVENT CEMENTING WITH PRIMER

1. Assemble proper materials for the job (proper cement, primer and applicator for the size of piping system to be assembled).
2. Pipe must be cut as square as possible. Use a hand saw and meter box or mechanical saw. A diagonal cut reduces bonding area in the most effective part of the joint.
3. Plastic tubing cutters may also be used for cutting plastic pipe; however, some produce a raised beed at the end of the pipe. This beed must be removed with a file or reamer, as it will wipe the cement away when pipe is inserted into the fitting.
4. Remove all burrs from both the inside and outside of the pipe with a knife, file or reamer. Burrs can scrape channels into pre-softened surfaces or created hang-ups inside surface walls.
5. Remove dirt, grease and moisture. A thorough wipe with a clean dry rag is usually sufficient. (Moisture will retard cure and dirt or grease can prevent adhesion.)
6. Check pipe and fittings for dry fit before cementing. For proper interference fit, fitting should go over end of pipe easily but become tight about 1/3 to 2/3 of the way on. Too tight a fit is not desirable; you must be able to fully bottom the pipe in the socket during assembly. If the pipe and fittings are not out of round, a satisfactory joint can be made if there is a "net" fit, that is, the pipe bottoms in the fitting socket with no interference, but with out slop. All pipe and fittings must conform to ASTM or other recognized standards.
7. Use the right application for the size of pipe or fittings being joined. The applicator size should be equal to 1/2 the pipe diameter. It is important that a satisfactory size applicator used to help ensure that sufficient layers of cement are applied.
8. Priming; the purpose of a primer is to penetrate and soften the surfaces so they can fuse together. The proper use of a primer and checking its softening effect provides assurance that the surfaces are prepared for fusion in a wide variety of conditions. Check the penetration or softening on a piece of scrap before you start the installation or if the weather changes during the day. Using a knife or other sharp object, drag the edge over the coated surface. Proper penetration has been made if you can scratch or scrape a few thousandths of the primed surfaces away. Because weather conditions do affect priming and cementing action, repeated applications to either or both surfaces may be necessary. In cold weather more time is required for proper penetration.
9. Using the correct applicator (as outlined in step #7), aggressively work the primer into fitting socket, keeping the surface and application wet until the surface has been softened. More application may be needed for hard surfaces and cold weather conditions, Re-dip the applicator in primer as required. When the surface is primed, remove any puddles of primer from socket.
10. Next, aggressively work the primer on to the end of the pipe to a point 1/2" beyond the depth of the fitting socket.
11. A second application of primer in the socket is recommended.
12. Immediately, and while the surfaces are still wet, apply the appropriate Weld-On cement.
13. Cementing; (Stir the cement or shake can before using). Using the proper size applicator for the pipe size, aggressively work a full even layer of cement on to the pipe end equal to the depth of the fitting socket - do not brush it out to a thin paint type layer, as this will dry within a few seconds.
14. Aggressively work a medium layer of cement into the fitting socket; avoid puddling cement in the socket. On bell-end pipe do not coat beyond the socket depth or allow cement to run down into the pipe beyond the bell.

INSTALLATION PROCEDURE

15. Apply a second full, even layer of cement on the pipe.
16. Without delay, while cement is still wet, assemble the pipe and fittings. Use sufficient force to ensure that the pipe bottoms in the fitting socket. If possible, twist the pipe a ¼ turn as you insert it. Stop turning when pipe hits bottoms.
17. Hold the pipe and fitting together for approximately 30 seconds to avoid push out.
18. After assembly, a joint should have a ring or bead of cement completely around the juncture of the pipe and fitting. If voids in this ring are present, sufficient cement was not applied and the joint may be defective.
19. Using a rag, remove the excess cement from the pipe and fitting, including the ring or bead, as it will needlessly soften the pipe and fitting and does not add to joint strength. Avoid disturbing or moving the joint.
20. Handle newly assembled joints carefully until initial set has taken place. Follow IPS Weld-On set and cure times before handling or testing piping system (for set and cure time refer to page 16.)

SOLVENT CEMENTING WITHOUT PRIMER

If local codes permit, successful joints can be made without a primer using cement alone, but extra care must be given to the installation. It is important that a good interference fit exists between the pipe and fittings. It is for this reason we recommend that joints being made without a primer be limited to system 2" and smaller applications (water systems only). Extra care must also be given in applying the cements to make sure proper penetration and softening of the pipe and fittings surfaces is achieved.

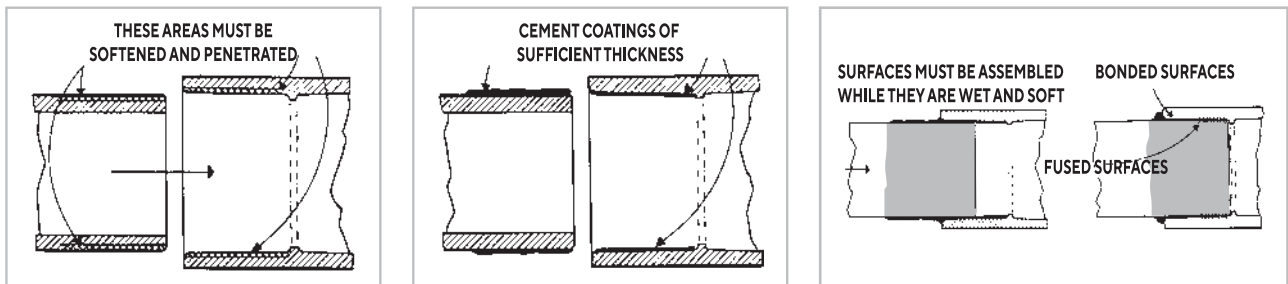

All information contained in this manual is given in good faith and believed to be accurate and reliable. But because of many factors which are outside our knowledge and control and affect use of product, no warranty is given or is to be implied with respect to such information, nor we offer any warranty of immunity against patent infringement. No responsibility can be accepted for any error, omissions or incorrect assumptions. Any specification can change without prior notice.

JOINING ASTRAL CHEMPRO CPVC PIPE AND FITTINGS – SOLVENT CEMENTING

RECOMMENDED SET TIMES

After a joint is assembled using solvent cement, it should not be disturbed for a period of time to allow for proper “setting” of the newly prepared joint. Recommended set times are as follows:

Ambient Temperature	½" to 1¼"	1½" to 3"	4" to 8"	10 to 12"
15° to 43°C	15 min	30 min	1 hr	2 hr
4° to 15°C	1 hr	2 hr	4 hr	8 hr
-17° to 4°C	3 hr	6 hr	12 hr	24 hr

RECOMMENDED CURE TIMES

After a joint is assembled using solvent cement, the cement must be allowed to properly “cure” before the piping system is pressurized. Recommended minimum cure times are shown below. These recommendations should only serve as a guide since atmospheric conditions during installation will affect the curing process.

High humidity and/or colder weather will require longer cure times: typically add 50% to the recommended cure time if surroundings are humid or damp.

CURE TIME FOR OPERATING/ TEST PRESSURES TO 1.24 MPa

Ambient Temperature	½" to 1¼"	1½" to 3"	4" to 8"	10 to 12"
15° to 43°C	1 hr	2 hr	6 hr	24 hr
4° to 15°C	2 hr	4 hr	12 hr	40 hr
-17° to 4°C	8 hr	16 hr	48 hr	8 days

CURE TIME FOR OPERATING/TEST PRESSURES ABOVE 1.24 MPa **

Ambient Temperature	½" to 1¼"	1½" to 3"	4" to 8"	10 to 12"
15° to 43°C	6 hr	6 hr	24 hr	24 hr
4° to 15°C	12 hr	24 hr	48 hr	40 hr
-17° to 4°C	48 hr	96 hr	8 days	8 days

**DO NOT exceed maximum working pressure of piping for given pipe size and operating temperature

JOINING ASTRAL CHEMPRO CPVC PIPE AND FITTINGS – SOLVENT CEMENTING

**TYPICAL RECOMMENDED MAXIMUM SUPPORT SPACING (IN METER)*
SCH 40 ASTRAL CHEMPRO CPVC PIPING NOMINAL PIPE SIZE**

Temp°C	½"	¾"	1"	1¼"	1½"	2"	2½"	3"	4"	6"	8"	10"	12"
16	1.52	1.68	1.83	1.83	1.98	1.98	2.29	2.44	2.59	2.90	2.90	3.05	3.20
27	1.52	1.52	1.68	1.68	1.98	1.83	2.13	2.13	2.29	2.44	2.44	2.74	3.05
38	1.37	1.52	1.68	1.68	1.98	1.83	2.13	2.13	2.29	2.44	2.44	2.74	3.05
49	1.37	1.37	1.52	1.68	1.68	1.68	1.98	2.13	2.13	2.29	2.29	2.44	2.74
60	1.22	1.22	1.37	1.52	1.52	1.52	1.83	1.83	1.98	2.13	2.13	2.29	2.44
82	0.76	0.76	0.76	0.91	0.91	0.91	1.07	1.07	1.22	1.37	1.52	1.68	1.83

**TYPICAL RECOMMENDED MAXIMUM SUPPORT SPACING (IN METER)*
SCH 80 ASTRAL CHEMPRO CPVC PIPING NOMINAL PIPE SIZE**

Temp°C	½"	¾"	1"	1¼"	1½"	2"	2½"	3"	4"	6"	8"	10"	12"
23	1.68	1.68	1.83	1.98	2.13	2.13	2.44	2.44	2.74	3.05	3.35	3.51	3.81
38	1.52	1.68	1.83	1.83	1.98	2.13	2.29	2.44	2.74	2.90	3.20	3.35	3.81
49	1.37	1.52	1.68	1.83	1.83	1.98	2.29	2.29	2.59	2.74	3.05	3.20	3.35
60	1.37	1.37	1.52	1.68	1.68	1.83	1.98	2.13	2.29	2.44	2.74	2.90	3.20
71	0.91	0.91	1.07	1.07	1.07	1.22	1.37	1.37	1.52	1.68	1.83	1.98	2.29
82	0.76	0.76	0.91	0.91	1.07	1.07	1.22	1.22	1.37	1.52	1.68	1.83	1.98

*Chart based on spacing for continuous spans and for uninsulated lines conveying fluids of specific gravity up to 1.00

GENERAL INSTALLATION GUIDELINES

Proper installation of Astral ChemPro CPVC piping systems is critical to the performance of the system. A few simple guidelines should be followed to ensure long service life and safe operation.

HANDLING

Proper care should be exercised when transporting or installing Astral ChemPro CPVC piping to prevent damage. Astral ChemPro CPVC piping should be stored and shipped only with other non-metallic piping. It should not be dropped or dragged during handling, especially during extremely cold weather. The same treatment should apply to the handling of Astral ChemPro CPVC fittings.

Prior to actual installation, the pipe and fittings should be thoroughly inspected for cracks, gouges, or other signs of damage. Particular attention should be given to the inside surface of the part. While the outside surface may not exhibit damage, improper handling can result in damage that appears only on the inside surface of the part.

CUTTING

Lengths of pipe can be easily and successfully cut by following a few simple guidelines. Best results are obtained by using fine-toothed saw blades (16 to 18 teeth per inch) with little or no offset (0.025" max.). Circular power saws (6,000 rpm) or band saws (3,600 ft./min.) are recommended using ordinary hand pressure. Miter boxes or other guide devices are strongly recommended for manual operation to ensure square cuts. Burrs, chips, and dust should be removed following cutting to prevent contamination of the piping system and facilitate joining.

JOINING METHODS

Astral ChemPro CPVC piping can be installed using a number of joining techniques. Solvent welding, flanging, and threading are the more common methods and are covered in greater detail in this section. Back welding of joints using hot gas welders is also covered in some detail.

HANGING / LAYING OF PIPE

Astral ChemPro CPVC piping can be installed above ground or buried underground. Methods to minimize stress on the piping as a result of installation are covered in detail below.

SYSTEM STRESS

Any metal or non-metal piping system is subject to stress-induced corrosion. As a result, special attention should be given to minimizing stress throughout the system. The total stress on a piping system includes not only the known pressure stress, but also stresses from sources such as expansion or installation. Expansion stresses can be minimized with expansion joints or loops. Installation stresses are minimized with careful installation techniques. Pipe and fittings should be properly prepared when joints are made up. Hangers and supports should be properly spaced to prevent sagging and should not cut into the pipe or clamp it tightly, preventing movement. System components should not be forced into place.

THERMAL EXPANSION

Astral ChemPro CPVC piping has the lowest coefficient of thermal expansion of any thermoplastic piping. However, thermal expansion will be greater than that of metal piping. Typically, expansion loops or offsets in the piping are designed to account for any thermal expansion. These design methods are covered in detail in our engineering design manual. Expansion joints can also be installed. Information on expansion joints can be obtained by contacting Astral Limited.

GENERAL INSTALLATION GUIDELINES

TESTING THE PIPING SYSTEM

After the piping system is installed and solvent cement is fully cured, the system should be pressure tested and checked for leaks using water. Testing using compressed air or inert gas is not recommended. All entrapped air should be allowed to vent as the system is filled with water. Water filling should occur at a velocity not more than 1ft/sec. After filling, the system should be pressured to 125% of the maximum design pressure of the lowest rated part of the system. Pressure should be held for no more than one hour while the system is checked for leaks.

FLANGING OF ASTRAL CHEMPRO CPVC PIPE

Flanging can be used to provide temporary disassembly of a piping system or when it is not possible to make up solvent cemented joints at the assembly site. Flanges are joined to the pipe by solvent cement or threaded joints. Refer to the sections on solvent cementing or threading of Astral ChemPro CPVC pipe for the proper techniques. Flanged joints incorporate an elastomeric gasket between the mating faces to provide for a seal. The gasket selected must be full-faced and have a hardness of 55-80 durometer A. Typically, gaskets are 1/8" thick. The gasket material must be resistant to the chemical environment. Many manufacturers of gasketing materials supply this kind of information. If the piping system is for potable water service, the gasket must also be approved for potable water. The flanges should be carefully aligned and the bolts inserted through matching holes. A flat washer should be used beneath each nut and bolt head. Each bolt should be partially tightened in the alternating sequence indicated here. A torque wrench should be used for the final tightening of the bolts. The bolts should be tightened to the torque recommended as per the table in the same alternating sequence used previously. Flange joints are typically rated to 150 psi at 23°C. For systems operating at higher temperatures, the flange pressure rating should be derated with the same derating factors which apply to the piping system pressure rating.

TECHNICAL INFORMATION

APPLICATION

Moulded CLASS 150 Flange fittings are coupling devices designed for joining IPS (Iron Pipe Size) plastic piping systems, where frequent disassembly may be required, and can be used as a transitional fitting for joining plastic to metal piping systems. Suitability of application is at the discretion of the user.

PRESSURE RATING

150 psi, water at 23°C.

FLANGE TYPES

One Piece — Available in socket configuration, sizes ½" through 8".

Van Stone Style — Two-piece design with rotating flange ring, available in socket configurations, sizes 1/2" through 16"; thread configurations, sizes 1/2" through 4" and spigot configurations, sizes 1/2" through 12"

Blind — Closed ring design for capping off a mating flange, flanged fitting or flanged valve, available in sizes 1/2" through 12".

MATERIALS

All injection molded flanges are produced from either PVC or CPVC materials approved for potable water use. Glass-filled PVC or CPVC materials may be used in certain Van Stone Style flange-rings and large diameter Blind flanges where additional reinforcement is deemed necessary.

CONFORMANCE STANDARDS

Socket & Spigot — ASTM D 2467 (PVC); ASTM F 439 (CPVC), as applicable.

Bolt Hole Pattern — ANSI B16.5; ASTM D 4024.

Material — ASTM D 1784 (PVC Cell Classification 12454-B, CPVC Cell Classification 23447-B).

RECOMMENDED BOLT TORQUE

Nominal Pipe Size	Number of Bolt Holes	Bolt Diameter (in)	Recommended Torque (N-m)
½ - 1½	4	1/2	13.6 - 20.4
2 - 3	4	5/8	27.2 - 40.8
4	8	5/8	27.2 - 40.8
6	8	3/4	44.8 - 68.0
8	8	3/4	44.8 - 68.0
10	12	7/8	72.1 - 102.0
12	12	1	108.8 - 149.6

Flange Bolt Tightening Patterns

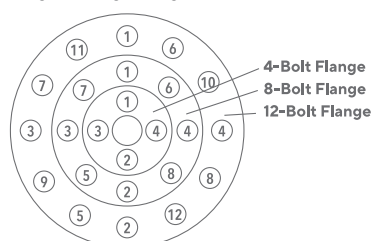

UNDERGROUND INSTALLATION GUIDELINES

REFERENCES

These guidelines are based upon the following :

1. ASTM D2774 : Standard Recommended Practice for Underground Installation of Thermoplastic Piping
2. Piping Manufacturer's Installation Instructions
3. Industry Experience For additional information and data, consult ASTM standards D2774, D2321, or F645.

INSTALLATION PROCEDURES

This procedure will cover the typical steps encountered in underground installations: trench design, trench preparation, piping assembly, laying of pipe, and backfilling.

TRENCH DESIGN

Width: The trench should be of adequate width to allow for convenient installation, but as narrow as possible depending on whether the piping will be assembled inside or outside of the trench.

Depth: The trench depth should be sufficient to place the pipe deep enough to meet frost, above-ground load, and any trench bedding requirements.

Frost: Piping at least 12 inches below the frost line.

Loads: Piping should be deep enough to keep external stress levels below acceptable design stress. Design stress will be determined by pipe size and operating temperature and may be governed by various codes.

Bedding: 4 to 6 inches underneath piping, if necessary.

TRENCH PREPARATION

The trench bottom should be continuous, relatively smooth and free of rocks. If ledge rock, hardpan, boulders, or rocks that are impractical to remove are encountered, it will be necessary to pad the trench bottom to protect the piping from damage. 4 to 6 inches of tamped earth or sand bedding will be sufficient in such situations.

PIPING ASSEMBLY/PLACEMENT

Piping may be assembled using conventional solvent cementing techniques either inside or outside of the trench depending on the specific installation requirements. Solvent cement usually requires at least 12 to 24 hours for the cemented joint to cure properly. During this critical curing process, every effort should be made to minimize the stress on any joints. As a result, the piping should not be moved during the curing period, nor should the pipe be backfilled, or otherwise constrained during curing. See the recommendations on joint curing time to determine the exact curing requirements for a specific installation.

If the piping was assembled outside of the trench, the pipe may be placed into the trench after proper curing, but **MUST NOT** be rolled or dropped into place. Long lengths of joined piping should be properly supported as the piping is put into place to prevent excessive stress.

After proper curing and before backfilling, the piping should be brought to within -9°C of the expected operating temperature. Backfilling can proceed while the piping is maintained at this temperature in order to minimize stress on the system due to thermal expansion/contraction. If this step is impractical, then stress calculations must be done to determine the loads that will be created due to constrained thermal expansion/contraction.* These loads must then be compared to the design stress of the particular piping system.

BACKFILLING

Backfilling should only proceed after all solvent cement joints have been properly cured and the piping brought close to normal operating temperature, if operation will be more than -9°C different than the current ambient temperature. The piping should be uniformly supported over its entire length on firm, stable material.

Backfill material should be free of rocks and have a particle size no greater than 1/2." Piping should initially be surrounded with backfill to provide between 6" and 8" of cover. The backfill should be compacted using vibratory or water flooding methods. If water flooding is used, additional material should not be added until the water flooded backfill is firm enough to walk on. Backfill containing a significant amount of fine-grained material, such as silt or clay, should be hand or mechanically tamped.

The remainder of the backfill should be placed and spread in approximately uniform layers to completely fill the trench without voids. Particle size for this final fill should not exceed 3. Rolling equipment or heavy tampers should only be used to consolidate the final backfill.

FOR ALL INSTALLATIONS

Do's

1. Install product according to Astral's Installation instructions and manual and follow recommended safe work practices.
2. Keep Pipe and Fittings in original packaging until needed and store pipes in covered areas.
3. Use tools designed for use with plastic pipe and fittings.
4. Always conduct hydraulic pressure testing after installation to detect any leaks and faults. Wait for appropriate cure time before pressure testing. Fill lines slowly and bleed air from the system prior to pressure testing.
5. Rotate the pipe 90° to 180° to spread the CPVC Solvent Cement evenly in the joint while pushing the Pipe into Fitting.
6. Ensure that there are no sharp edges in contact with the pipe while embedding the pipes.
7. Provide Vertical & Horizontal Supports as recommended.
8. Apply a water- based only paint on exposed pipes & fittings
9. Visually inspect all joints for proper cementing at the end of shift or day. A Visual inspection of the complete system is also recommended during pressure testing

Do Not's

1. Do not use Nails to hold or put pressure on the pipes. Do not use straps & hangers with rough or sharp edges. Do not over tighten the straps on the pipes.
2. Never expose the pipe to Open Flame while trying to bend it.
3. Do not drop pipes on edges from heights. Do not drop heavy objects on pipes or walk on pipes.
4. Do not dilute Solvent Cement with Thinners /MTO or any other liquid etc.
5. Do not use air or gases for pressure testings.
6. Do not use any other petroleum or solvent- based sealant, adhesive, lubricant or fire stop material on CPVC pipes and fittings.
7. Do not use CPVC Pipes & Fittings for pneumatic applications.

COMPARISON OF CHEMPRO WITH MSRL

ASTRAL CHEMPRO CPVC - MSRL

Sr. No.	Factor	Msrl	Astral CHEMPRO CPVC	Advantages of Astral CHEMPRO CPVC
1)	a) External	Mild steel corrodes when it comes in contact with acid fumes or even in normal atmospheric conditions.	Astral ChemPro CPVC is resistant to acid fumes and even very harsh atmospheric conditions.	No failure of system due to corrosion.
	b) Internal	Rubber lining is inconsistent both in terms of rubber quality and workmanship. It results in localized corrosion which leads to leakage.	Astral ChemPro CPVC has excellent chemical resistance to all mineral acids and bases.	No failure of system due to corrosion.
2)	Failure detection	As a consequence of above, it is very difficult to predict the spread of corrosion.	Astral ChemPro CPVC is impervious to both galvanic as well as chemical attack.	This leads to minimum maintenance and a long service life.
3)	Joining method	Flanged joints using bolts.	Socket Joints.	This eliminates the need flanged and Reduces the installation time considerable. Hence, easy Installation and less cost. Also it Reduces the chances of failure of Flange Gaskets and hence minimize down time.
4)	Friction loss	Rubber lined surface is very rough, hence high friction losses.	Very smooth internal surface Results in minimum friction Losses.	Less friction losses results higher flow rates compared MSRL Pipe of same size. The effectively means that for given flow rate there is less power consumption results in direct savings in operatic cost.
5)	Biological Growth	Due to rough internal surface there is biological growth.	Astral ChemPro CPVC is resistance to actions of all form of bacteria such as Iron oxidizing bacteria, Sulphate, reducing bacteria and acid producing bacteria.	This eliminates the chances contamination of the fluid and corrosion.
6)	Actual Bore	Due to thickness of rubber Lining actual bore is reduced. Example 2" MSRL pipe has only 46mm bore.	In case of Astral ChemPro CPVC SCH-40 pipe 2' size has actual bore of 52mm.	A smaller size CPVC pipe substitute a MSRL pipe for givensize e.g. 1.¼" MSRL pipe can be replaced by CPVC pipe.
7)	Maintenance	Due to poor corrosion resistance frequent changing of pipes is required.	Superior resistance to most corrosive chemicals and also no scaling makes the system maintenance free.	Minimum or No Maintenance cost.
8)	Life of piping system	Due to the reasons listed above life of MSRL is unpredictable.	Astral ChemPro CPVC is working successfully in most of the installations.	Astral ChemPro CPVC piping has long life than comparison MSRL.

ASTRAL CHEMPRO CPVC - HDPE

Sr. No.	Factor	HDPE	Astral CHEMPRO CPVC	Advantages of Astral CHEMPRO CPVC
1)	Physical properties a) Specific gravity b) Tensile strength [PSI@26°C] c) Flexural Strength [PSI] d) Co-efficient of Thermal expansion [in./in/°F X 105] e) Thermal conductivity [BTU.hr/ft2/°F/in]	0.95 3300 3000 7.8 7.0	1.55 8400 15350 3.8 3.0	Physical properties of Astral ChemPro CPVC piping system are superior when compared to HDPE
2)	Fire properties	HDPE supports combustion	Astral ChemPro CPVC does not support combustion.	Astral ChemPro CPVC can be also used in highly fire-prone areas
3)	Support structure	Supports have to be provided at frequent intervals or it has to be supported throughout by using cable trays. e. g. at 30°C at 90 mm HDPE class IV [10 kg / cm2] pipe needs supports at 125mm.	Fewer supports are required in comparison with HDPE. e.g. . at 30°C Astral ChemPro CPVC SCH-40 pipe needs supports at 2134 mm	Costs for supports for Astral ChemPro CPVC will be much lower.
4)	Maximum service temperature	HDPE is not recommended to be used for temperature above 55°C.	Astral ChemPro CPVC is recommended to be used for operating temperature of 93°C.	This gives a high factor of safety which result in a much longer life as compared to HDPE.
5)	Joining Method	a) HDPE is joined by buttwelding process which need special equipment and high skill. b) Butt welded joints form an internal protrusion which prevents smooth flow and hence higher friction losses. Also internal protrusion erodes with time and contaminates the fluid.	a) Astral ChemPro CPVC is joined by solvent cementing which required no special tools and does not need high skill level. b) Astral ChemPro CPVC solvent cemented joints do not pose such problems.	a) Joining method CPVC is easier than HDPE which reduces installation time and hence reduces the cost. b) Less friction losses results in higher flow rates compared to HDPE pipe of same size. This effectively means that for a given flow rate there is less power consumption resulting in direct saving in operating cost. Also it can be used where purity of fluid is required.
6)	Life of system	Less due to the above reasons	Life of Astral ChemPro CPVC is much higher.	Life of CPVC is much higher than HDPE for the same applications due to much higher safety factor.

COMPARISON OF CHEMPRO WITH FRP/PVC/PP

ASTRAL CHEMPRO CPVC - FRP/PVC/PP

Sr. No.	Factor	FRP/PVC/PP	Astral CHEMPRO CPVC	Advantages of Astral CHEMPRO CPVC
1)	Service Temperature	Both PVC as well as PP become soft above a service temperature of 60°C. In order to enhance mechanical strength they have to be reinforced with FRO coating. Even with this reinforcement, they are not recommended for service / temperature above 80°C.	Astral ChemPro CPVC is recommended for 93°C for continuous operation.	Since Astral ChemPro CPVC has a much higher service temperature, it gives a better safety factor than FRP - PVC / PP
2)	Jointing a) Method	FRP-PVC/PP is joined by using glass mat and catalyses resin. This requires a high skill level.	Astral ChemPro CPVC is joined by using solvent cement. This does not require a high skill level.	Solvent cementing joining is very simple and does not require a high skill level.
	b) Time	Time consuming since it involves fibre glass laying, resin preparation, resin application and resin curing.	Very quick only involves solvent cement application on two surfaces, press fitting the two ends and allow for setting of joint.	Due to less time required for each joint, over all the Astral ChemPro CPVC piping system is ready for use in a far less time as compared to FRP.
3)	Installation cost	High, since it needs high skill levels as well as more time.	Low, since it needs low skill levels and less time.	Astral ChemPro CPVC industrial piping system has lower installation cost.
4)	Thermal Expansion	PVC/PP has a much higher thermal expansion than FRP. This results in : a) Loosening of FRP layer which in turn will lead to sagging of pipe and hence leakage at the joints. b) High stresses since the FRP layer will not allow it to expand and will lead to crack in pipes	Astral ChemPro CPVC is an integral piping system consisting of one material in the entire piping system.	Astral ChemPro CPVC will not fail due to thermal expansion.
5)	Maintenance	Due to frequent leakage and high failure rate, frequent maintenance is required.	Astral ChemPro CPVC system requires minimum maintenance.	Astral ChemPro CPVC system is very convenient in the maintenance point of view.
6)	Life	Maximum service life is between 5-6 years since the properties of both the polymers i. e. PVC/PP deteriorate very rapidly at higher service temperatures.	Astral ChemPro CPVC industrial piping system is being used successfully all over the world in most installations.	Astral ChemPro CPVC has higher life expectancy than FRP-PVC/PP.
7)	Cost of system	Taking the material cost, installation cost, operation cost, maintenance cost as well as life of the system, FRP PVC/PP has a higher cost.	Keeping the enlisted factors in mind, ASTRAL CHEMPRO CPVC has much lower cost.	Astral ChemPro CPVC Industrial Piping System is cost effective as compared to FRP-PVC/PP.

CHEMICAL RESISTANCE OF ASTRAL CHEMPRO

Chemical	Concentration	CPVC °C	Chemical	Concentration	CPVC °C
Acetaldehyde	--	N	Anthraquinone	--	82
Acetic Acid	Aq. of 40%	N	Antimony Trichloride	Sat's	82
	vapor	82	Aqua Regia	--	R to 23
	25%	82	Arsenic Acid	80%	82
	60%	N	Aryl Sulfonic Acid	--	82
	85%	N	Asphalt	--	N
	glacial	N	Barium Carbonate	Sat's	82
Acetic Anhydride	--	N	Barium Chloride	Sat's	82
Acetone	5%	N	Barium Hydroxide	Sat's	82
Acetyl Chloride	--	N	Barium Nitrate	Sat's	82
Acetylene	gas 100%	N	Barium Sulfate	Sat's	82
Acetylnitrile	--	N	Barium Sulfide	Sat's	82
Acrylic Acid	97%	N	Beer	--	82
Acrylonitrile	--	N	Beet Sugar Liquors	--	82
Adipic Acid	Sat's	82	Benzaldehyde	10%	R to 23
Allyl Alcohol	96%	C to 23	Benzene	--	N
Allyl Chloride	--	N	Benzene Sulfonic Acid	10%	82
Aluminum Ammonium Sulfate (Alum)	Sat's	82		10%+	N
Aluminum Chloride Aqueous	Sat's	82	Benzoic Acid	all	82
Aluminum Fluoride Anhydrous	Sat's	82	Benzyl Alcohol	--	N
Aluminum Hydroxide	Sat's	82	Bismuth Carbonate	Sat'd.	82
Aluminum Nitrate	Sat's	82	Black Liquor	Sat's	82
Aluminum Oxochloride	--	82	Bleach	5% Active Cl ₂	82
Aluminum Potassium Sulfate	Sat's	82		12% Active Cl ₂	85
Aluminum Sulfate (Alum)	Sat's	82	Borax	Sat's	82
Ammonia Gas	100%	N	Boric Acid	Sat's	82
Ammonia Liquid	100%	N	Brine	Sat's	82
Ammonium Acetate	Sat's	82	Bromic Acid	Sat's	82
Ammonium Bifluoride	Sat's	82	Bromine	Liquid	N
Ammonium Carbonate	Sat's	82		vapor 25%	82
Ammonium Chloride	Sat's	82	Bromine Water	cold Sat's	82
Ammonium Fluoride	10%	82	Butadiene	50%	82
	25%	82	Butane	50%	82
Ammonium Hydroxide	10%	N	Butyl Acetate	100%	N
Ammonium Nitrate	Sat's	82	Butyl Alcohol	--	C to 23
Ammonium Persulfate	--	82	Butyl Cellosolve	--	N
Ammonium Phosphate (Monobasic)	all	82	n-Butyl Chloride	--	N
Ammonium Sulfate	Sat's.	82	Butyl Phthalate	--	N
Ammonium Sulfide	dilute	82	Butyric Acid	--	N
Ammonium Thiocyanate	50-60%	82	Cadmium Cyanide	--	82
Amyl Acetate	--	N	Calcium Bisulfide	--	R to 23
Amyl Alcohol	--	N	Calcium Bisulfite	--	82
n-Amyl Chloride	--	N	Calcium Carbonate	Sat's	82
Aniline	--	N	Calcium Chlorate	--	82
Aniline Chlorohydrate	--	N	Calcium Chloride	Sat's	82
Aniline Hydrochloride	Sat's	N	Calcium Hydroxide	--	82
			Calcium Hypochlorite	30%	82
			Calcium Nitrate	--	82
			Calcium Oxide	--	82
			Calcium Sulfate	--	82
			Cane Sugar Liquors	--	82

CHEMICAL RESISTANCE OF ASTRAL CHEMPRO

Chemical	Concentration	CPVC °C	Chemical	Concentration	CPVC °C
Carbitol	--	N	Cresylic Acid	50%	82
Carbon Dioxide	Dry 100%	82	Crotonaldehyde	--	N
	Wet	71	Crude Oil	--	C to 82
Carbon Disulfide	--	N	Cupric Fluoride	--	82
Carbon Monoxide	Gas	82	Cupric Sulfate	Sat's	82
Carbon Tetrachloride	--	N	Cuprous Chloride	Sat's	82
Carbonic Acid	Sat's	82	Cyclohexane	--	N
Castor Oil	--	C to 82	Cyclohexanol	--	N
Caustic Potash	50%	82	Cyclohexanone	Liquid	N
Caustic Soda (Sodium Hydroxide)	40%	82	Dextrin (Starch Gum)	Sat's	82
Cellosolve	--	N	Dextrose	Sat's	82
Cellosolve Acetate	--	N	Diacetone Alcohol	--	N
Chloral Hydrate	All	82	Dibutoxyethyl Phthalate	--	N
Chloramine	Dilute	N	Dibutyl Phthalate	--	N
Chloric acid	10%	82	Dichlorobenzene	--	N
	20%	85	Dichloroethylene	--	N
Chlorine Gas	0-20 PPM moisture content	C to 23	Diesel Fuels	--	C to 82
	20-50 PPM moisture content	N	Diethylamine	--	N
	50+ PPM moisture content	N	Diethyl Ether	--	N
Chlorine	Liquid	N	Diglycolic Acid	Sat's	82
Chloroacetic Acid	50%	82	Dimethylformamide	--	N
Chlorobenzene	Dry	N	Dimethyl Phthalate	--	N
Chlorobenzyl Chloride	--	N	Diocetyl Phthalate	--	N
Chloroform	Dry	N	Dioxane	--	N
Chlorosulfonic Acid	--	R to 23	Disodium Phosphate	--	82
	10%	82	Ether ROR	--	N
	30%	82	Ethyl Acetate	--	N
	40%	82	Ethyl Acetoacetate	--	N
	50%	C to 60	Ethyl Acrylate	--	N
Citric Acid	Sat's	82	Ethyl Alcohol (Ethanol)	--	N
Coconut Oil	--	C to 82	Ethyl Chloride	Dry	N
Coffee	--	82	Ethyl Ether	Liquid	N
Copper Acetate	Sat's	R to 23	Ethylene Bromide	Dry	N
Copper Carbonate	Sat's	82	Ethylene Chloride (Vinyl Chloride)	Dry	N
Copper Chloride	Sat's	82	Ethylene Chlorohydrin	--	N
Copper Cyanide	Sat's	82	Ethylene Dichloride	Dry	N
Copper Fluoride	2%	82	Ethylene Glycol	Liquid	C to 82
Copper Nitrate	30%	82	Ethylene Oxide	--	N
Copper Sulfate	Sat's	82	Fatty Acids	--	71
Corn Oil	--	C to 82	Ferric Chloride (Aqueous)	Sat's	82
Corn Syrup	--	85	Ferric Hydroxide	Sat's	82
Cottonseed Oil	--	C to 82	Ferric Nitrate	Sat's	82
Creosote	--	N	Ferric Sulfate	--	82
Cresol	90%	N	Ferrous Chloride	Sat's	82
			Ferrous Hydroxide	Sat's	82
			Ferrous Nitrate	--	82
			Ferrous Sulfate	--	82
			Ferrous Chloride	Sat's	82
			Fish Oil	--	82
			Fluoroboric Acid	--	R to 23

Chemical	Concentration	CPVC °C
Fluorine Gas (Dry)	100%	R to 23
Fluorine Gas (Wet)	--	R to 23
Fluorosilicic Acid	30%	R to 60
	50%	R to 23
Formaldehyde	Dilute	R to 23
	35%	C to 23
	37%	C to 23
	50%	C to 23
Formic Acid	--	C to 23
Freon 11	100%	R to 23
Freon 12	100%	R to 23
Freon 22	100%	R to 23
Fructose	Sat's	82
Furfural	100%	N
Gasoline, Leaded*	--	N
Gasoline, Unleaded*	--	N
Gasohol*	--	N
Gasoline, Sour*	--	N
Gelatin	--	82
Glucose	--	82
Glycerine	--	82
Glycol	--	C to 82
Glycolic Acid	Sat's	82
Grape Sugar	--	82
Green Liquor	--	82
Heptane (Type 1)	--	82
n-Hexane	--	R to 23
Hexanol, Tertiary Type I	--	82
Hydrazine	--	N
Hydrobromic Acid	20%	R to 23
Hydrochloric Acid	10%	82
	30%	82
Hydrocyanic Acid	--	82
Hydrofluoric Acid	Dilute	R to 23
	30%	R to 23
	50%	N
	100%	N
Hydrogen	Gas	R to 23
Hydrogen Peroxide	50%	82
	90%	82
Hydrogen Sulfide	Dry	82
	Wet	82
Hydroquinone	Sat's	82
Hydroxylamine Sulfate	--	82
Hypochlorous Acid	10%	82
Iodine	10%	R to 23
Isobutyl Alcohol	--	C to 23
Isopropyl Acetate	--	N
Isopropyl Alcohol	--	C to 82
Isopropyl Ether	--	N
Kerosene*	--	R to 23

Chemical	Concentration	CPVC °C
Ketones	--	N
Kraft Liquors	--	82
Lactic Acid	25%	82
	80%	C to 18
Lard Oil	--	C to 18
Lauric Acid	--	82
Lauryl Chloride (Type I)	--	R to 23
Lead Acetate	Sat's	82
Lead Chloride	--	82
Lead Nitrate	Sat's	82
Lead Sulfate	--	82
Lemon Oil	--	N
Lime Sulfur	--	R to 23
Linseed Oil	--	R to 23
Magnesium Carbonate	--	48
Magnesium Chloride	Sat's	82
Magnesium Citrate	--	82
Magnesium Hydroxide	Sat's	82
Magnesium Nitrate	--	82
Magnesium Sulfate	--	82
Maleic Acid	Sat's	82
Malic Acid	--	82
Manganese Sulfate	--	82
Mercuric Chloride	--	82
Mercuric Cyanide	Sat's	82
Mercuric Sulfate	Sat's	82
Mercurous Nitrate	Sat's	82
Mercury	Liquid	82
Methane	--	R to 23
Methanol (Methyl Alcohol)	--	N
Methyl Acetate	--	N
Methyl Amine	--	N
Methyl Bromide	--	N
Methyl Cellosolve	--	N
Methyl Chloride	Dry	N
Methyl Chloroform	--	N
Methyl Ethyl Ketone (MEK)	100%	N
Methyl Isobutyl Carbinol	--	N
Methyl Isobutyl Ketone	--	N
Methyl Isopropyl Ketone	--	N
Methyl Methacrylate	--	N
Methyl Sulfate	--	R to 23
Methylene Bromide	--	N
Methylene Chloride	100%	N
Methylene Chlorobromide	--	N
Methylene Iodide	--	N
Methylsulfuric Acid	--	82
Milk	--	82
Mineral Oil	--	82
Molasses	--	82
Monochlorobenzene	Tech Pure	N

CHEMICAL RESISTANCE OF ASTRAL CHEMPRO

Chemical	Concentration	CPVC °C	Chemical	Concentration	CPVC °C
Motor Oil	--	82	Potassium Bromate	--	82
Naphtha	--	R to 23	Potassium Bromide	--	82
Naphthalene	--	N	Potassium Carbonate	--	82
Nickel Chloride	Sat's	82	Potassium Chlorate	--	71
Nickel Nitrate	Sat's	82	(Aqueous)	--	71
Nickel Sulfate	Sat's	82	Potassium Chloride	Sat's	82
Nicotine	--	82	Potassium Dichromate	--	82
Nicotinic Acid	--	82	Potassium Ferricyanide	--	82
Nitric Acid	10%	82	Potassium Ferrocyanide	--	82
	30%	R to 64	Potassium Fluoride	--	82
	40%	R to 48	Potassium Hydroxide	25%	82
	50%	43	Potassium Hypochlorite	--	82
	70%	37	Potassium Iodide	--	82
	100%	N	Potassium Nitrate	--	82
Nitrobenzene	100%	N	Potassium Perborate	--	82
Nitrous Acid	10%	82	Potassium Perchlorate	--	82
Nitrous Oxide	--	R to 23	Potassium Permanganate	10%	82
n-Octane	--	C to 23		25%	82
Oleic Acid	--	71	Potassium Persulfate	--	82
Oleum	--	N	Potassium Sulfate	--	82
Olive Oil	--	71	Potassium Sulfide	--	82
Oxalic Acid	50%	82	Potassium Sulfite	--	82
Oxygen Gas	--	82	Propane	--	R to 23
Ozone	--	82	Propargyl Alcohol	--	C to 82
Palmitic Acid	10%	R to 23	Propionic Acid	--	N
	70%	R to 23	Propyl Alcohol (Type I)	--	R to 23
Paraffin	--	82	Propylene Dichloride	100%	N
Peanut Oil	--	C to 82	Propylene Oxide	--	N
n-Pentane	--	C to 82	Pyridine	--	N
Perchloric Acid (Type I)	15%	82	Rayon Coagulating Bath	--	82
	70%	82	Selenic Acid Aq.	--	82
Perchloroethylene (tetrachloroethylene)	--	N	Silicic Acid	--	82
Perphosphate	--	R to 23	Silicone Oil	--	82
Phenol	--	R to 23	Silver Chloride	--	82
Phenylhydrazine	--	N	Silver Cyanide	--	82
Phosphoric Acid	10%	82	Silver Nitrate	--	82
	50%	82	Silver Sulfate	--	82
	85%	82	Soaps	--	82
Phosphoric Anhydride	--	R to 23	Sodium Acetate	Sat's	82
Phosphorus Pentoxide	--	R to 23	Sodium Alum	--	82
Phosphorus Trichloride	--	N	Sodium Benzoate	--	82
Photographic Solutions	--	82	Sodium Bicarbonate	--	82
Picric Acid	10%	N	Sodium Bisulfate	--	82
Pine Oil	--	N	Sodium Bisulfite	--	82
Potash (Aq)	Sat's	82	Sodium Borate (Borax)	Sat's	82
Potassium Alum	--	82	Sodium Bromide NaBr	Sat's	82
Potassium Bicarbonate	Sat's	82	Sodium Carbonate	--	82
Potassium Bi-chromate	Sat's	82	Sodium Chlorate	Sat's	82
Potassium Bisulfate	--	82	Sodium Chloride	--	82
Potassium Borate	--	82	Sodium Chlorite	25%	82
			Sodium Chromate	--	82

Chemical	Concentration	CPVC °C
Sodium Cyanide	--	82
Sodium Dichromate	Sat's	82
	20%	82
Sodium Ferricyanide	Sat's	82
Sodium Ferrocyanide	Sat's	82
Sodium Fluoride	--	82
Sodium Hydroxide	15%	82
	30%	82
	50%	82
	70%	82
Sodium Hypochlorite	--	82
Sodium Iodide	--	82
Sodium Metaphosphate	--	82
Sodium Nitrate	Sat's	82
Sodium Nitrite	--	82
Sodium Palmitate	5%	82
Sodium Perborate	--	82
Sodium Perchlorate	--	82
Sodium Peroxide	10%	82
Sodium Phosphate	Acid	82
	Alkaline	48
	Neutral	48
Sodium Silicate	--	82
Sodium Sulfate	Sat's	82
Sodium Sulfide	Sat's	82
Sodium Sulfite	Sat's	82
Sodium Thiosulfate	--	82
Stannic Chloride	Sat's	82
Stannous Chloride	15%	82
Starch	--	82
Stearic Acid	--	82
Stoddard's Solvent	--	N
Succinic Acid	--	82
Sugar	Aq.	82
Sulfamic Acid	20%	N
Sulfate Liquors (Oil)	6%	82
Sulfite Liquors	6%	82
Sulfur	--	82
Sulfur Dioxide	Gas Dry	R to 23
	Gas Wet	N
Sulfur Trioxide	Gas	N
Sulfuric Acid	30%	82
	50%	82
	60%	82
	70%	82
	80%	82
	90%	65
	93%	60
	94%-96%	64
	Above 96%-98%	**
	100%	N

Chemical	Concentration	CPVC °C
Sulfurous Acid	--	82
Tall Oil	--	C to 82
Tannic Acid	10%	82
Tanning Liquors	--	82
Tar	--	N
Tartaric Acid	--	82
Tetrachloroethylene	--	N
Tetraethyl Lead	--	R to 23
Tetrahydrofuran	--	N
Tetralin	--	N
Toluene (Toluol)	--	N
Trichloroethylene	--	N
Triethanolamine	--	R to 23
Trisodium Phosphate	--	R to 23
urpentine	--	N
Urea	--	82
Urine	--	82
Vinegar	--	R to 23
Water, Acid Mine	--	71
Water, Deionized	--	71
Water, Distilled	--	71
Water, Potable	--	71
Water, Salt	--	71
Water, Sea	--	71
Water, Soft	--	71
Water, Waste	--	R to 23
White Liquor	--	R to 23
Wine	--	R to 23
Xylene (Xylol)	--	N
Zinc Acetate	--	82
Zinc Carbonate	--	82
Zinc Chloride	--	82
Zinc Nitrate	--	82
Zinc Sulfate	--	82

N - Not Resistance

R to 23 - Resistance to 23°C

C - Use with Caution

** - Contact Astral

N.B.:- For chemicals other than listed here and for temperature from 82°C to 93°C, please contact us to check suitability of CPVC CHEMPRO.

PARTIAL REFERENCE LIST OF CLIENTS FOR ASTRAL PIPING SYSTEMS

Sr. No.	Name of The Company	Location
01	Atul Limited	Valsad
02	Adani Power Limited	Mundra, Tiroda, Kawani
03	Aditya Cement Limited	Chitorghar
04	Ashima Textile Ltd.	Ahmedabad
05	Aker Powergas Pvt. Ltd	Mumbai
06	Aban Offshore Ltd.	Mumbai
07	Bharat Heavy Electricals Limited	Ranipat, Rudrapur, Chennai
08	BGR Energy system Limited	Chennai
09	B.A.S.F	Bangalore
10	Binani Cement Limited	Sirohi
11	Cadila Pharmaceuticals Ltd.	Ahmedabad
12	Coromandel Fertilisers Ltd.	Visakhapatnam, A.P.
13	Chennai Petroleum Corporation Ltd.	Chennai
14	Damodar velly Corporation Limited	Chandrapur
15	Dr. Reddys Laboratory	Hydrabad
16	Doshion Veolia Water Solutions Pvt. Ltd	Ahmedabad
17	EngineersIndia Limited	Delhi
18	Fertilizers and Chemicals Travancore Ltd.	Kochi, Kerala
19	Grasim Industries Ltd.	Nagda, Havery
20	G. M. D. C.	Panandhro, Kutchh
21	Gujarat Electricity Corporation Ltd	Gujarat
22	GIPCL	Vadodara
23	G A I L	Pata, U. P.
24	Hindustan Newsprint Ltd.	Kottayam, Kerala
25	Hindustan Dorr-Oliver Limited	Mumbai
26	Hindustan Organic chemicals	Rasayani
27	Hindalco Industries Ltd.	Renukoot, Renusagar (Power)
28	Hindustan Unilever Limited	Hardwar
29	Hindustan Petroleum Limited	Mumbai
30	Haldia Petrochemicals Ltd.	Haldia
31	Hindustan Zinc Limited	Debari-Udaipur, Vizag
32	Indo Gulf Fertilisers Ltd.	Sultanpur
33	Indian Farmers Fertilizers Co Op Ltd	Kalol, Kandla, Phulpur
34	ION Exchange India Limited	Mumbai, Goa, Hosur, Delhi
35	Jindal Power Ltd.	Raigarh, Bellary
36	Krishak Bharati Co-operative Limited	Surat
37	Kerala Minerals And Metals	Kollam, Kerala
38	Karnataka Power Corporation Limited	Raichur
39	Kanoria Chemicals and Industries Ltd.	Renukoot
40	Lanco Industries Limited	Chittoor
41	Larson & Toubro Ltd.	Delhi, Hazira, Chennai
42	Maharashtra State Electricity Board	Chandrapur, Parash, Khaperkheda
43	Manglore Refinery & Petro Chemicals Ltd. (ONGC)	Manglore
44	Manglore Chemicals & Fertilizers	Manglore
45	Monet Ispat Limited	Raigarh
46	National Thermal Power Corporation	Ambedkar Nagar, Vidhyachal, Rihand
47	Nagarjuna Fertilizers & Chemicals Limited	Kakinada
48	Nuclear Power Corporation Of India Ltd.	Tarapur
49	Oil & Natural Gas Corporation Offshore Project	Mumbai, Ankleshwar
50	Ratnagiri Gas & Power Limited	Ranagiri
51	Riddhi Siddhi Gluco Biols Limited	Viramgam, Uttam Nagar, Gokak
52	Rashtriya Chemicals And Fertilizers Ltd.	Mumbai
53	Reliance Energy	Yamunanagar
54	Reliance Industries Limited	Mumbai, Jamnagar, Nagpur
55	Rajasthan State Electricity Board	Jaipur
56	Shree Kamrej Vibhag Sahakari Khand Udyog Mandli Ltd.	Kamrej, Surat
57	Shriram Vinyl & Chemical Industries	Kota and Jagadiya
58	Steel Authority of India	Rourkela, Orissa
59	Siel Chemicals	Rajpura
60	Sterlite Industries	Tuticorin
61	Torrent Power Ltd.	Ahmedabad
62	Tata Chemicals Ltd.	Mithapur, Haldia, Babrala
63	The Associated Cement Company Limited	Bhillai
64	Triveni Engineering & Industries Limited	Noida
65	Tamil Nadu News Print and Papers Limited	Karur
66	The Tata Steel	Jamshedpur, Kabilpore
67	The Andhra Pradesh Paper Mills Limited	Rajamundry
68	The Travancore - Cochin Chemicals Limited	Kochi, Kerala
69	Thermax India Limited	Pune
70	VA Tech Wabag Ltd	Chennai
71	Visakhapatnam Steel Plant	Visakhapatnam
72	Western India Ship Yard Ltd	Goa
		and many more.....



*A consumer validated
Superbrand in piping
category for
consecutive 3 years*



*India's Most Trusted
Pipe Brand based on
TRA's Brand Trust
Report for the 4th time*

Power of Desire



*India's Most Desired
Brand based on
TRA's Brand Trust
Report 2021*



CIN NO: L25200GJ1996PLC029134

Registered & Corporate Office: Astral Poly Technik Limited

207/1, 'Astral House', B/h Rajpath Club, Off S. G. Highway, Ahmedabad - 380059.

Ph: +91-79 6621 2000 | Fax: +91-79 6621 2121 | E-mail: info@astralpipes.com | Website: www.astralpipes.com

For Export Inquiries: export@astralpipes.com



**ASTRAL TOLL FREE
1800 233 7957**

Please get in touch with us between
10 AM to 6 PM on Monday to Saturday-except
1st & 3rd Saturday and Public holidays

SC: PR07000042
ACH/PCN/002
REV:07/22