

Pneumatic linear cylinder actuator Series VCC

Installation, maintenance and
operating instructions

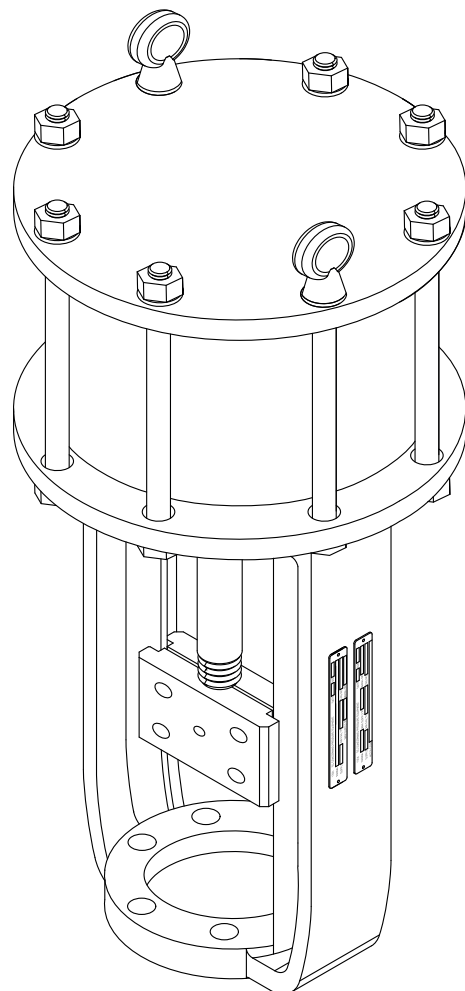

Table of Contents

GENERAL	3	MALFUNCTIONS	10
Scope of the manual	3	TOOLS	10
Structure and operation	3	ORDERING SPARE PARTS	10
Actuator markings	3	EXPLODED VIEWS AND PARTS LISTS	11
Specifications	3	DIMENSIONS AND WEIGHTS	12
Recycling and disposal	4	TYPE CODE	14
Safety precautions	4		
TRANSPORTATION, RECEPTION AND STORAGE	4		
MOUNTING AND REMOVAL	5		
Actuator air supply	5		
Mounting the actuator on the valve	5		
Removal the actuator from the valve	5		
MAINTENANCE	6		
General	6		
Replacement seals for VC	6		
Operation the handwheel	7		
Removal the handwheel subassembly	9		
Adjustment for valve stem	9		

READ THESE INSTRUCTIONS FIRST!

These instructions provide information about safe handling and operation of the actuator.

If you require additional assistance, please contact the manufacturer or manufacturer's representative.

Addresses and phone numbers are printed on the back cover.

See also www.neles.com/valves for the latest documentation.

SAVE THESE INSTRUCTIONS!

Subject to change without notice.

All trademarks are property of their respective owners.



This product meets the requirements set by the Customs Union of the Republic of Belarus, the Republic of Kazakhstan and the Russian Federation.

1 GENERAL

1.1 Scope of the manual

This manual provides essential information on Neles series VC, linear double-acting pneumatic cylinder actuators. Valve body and trims are only discussed briefly. Refer to the individual manuals for further information on their installation, operation and maintenance.

NOTE:
 Selection and use of the actuator in a specific application requires close consideration of detailed aspects. Due to the nature of the product, this manual cannot cover all the individual situations that may occur when the actuator is used.
 If you are uncertain about use of the actuator or its suitability for your intended purpose, please contact Neles for more information.

1.2 Structure and operation

Neles series VC are linear double-acting pneumatic cylinder actuators. Excellent accuracy and reliability is achieved through the use of piston and well fitted seal rings in the actuator.

The VC double acting cylinder actuators are designed for use in both modulating control and on-off service. They provide heavy duty and reliable operation and are well suited for many different kind of applications. The high performance internal coating resists wear and corrosion and the replaceable inner parts guarantee a long life cycle.

When "stay put" failure mode is required, a double acting actuator with lock up valve is the correct choice. If another failure is required, a double acting actuator with transfer valve and a volume chamber should be selected. The series VC pneumatic cylinder actuators are available with a built-in volume chamber or with an independent volume tank to provide failure in either open or closed position.

The built-in volume chamber provides minimum one time stroking when the instrument air fails.

Optional handwheel is available for manual operation. The detailed structure is revealed by the type code shown on the valve identification plate. The type code is explained in Section 10.

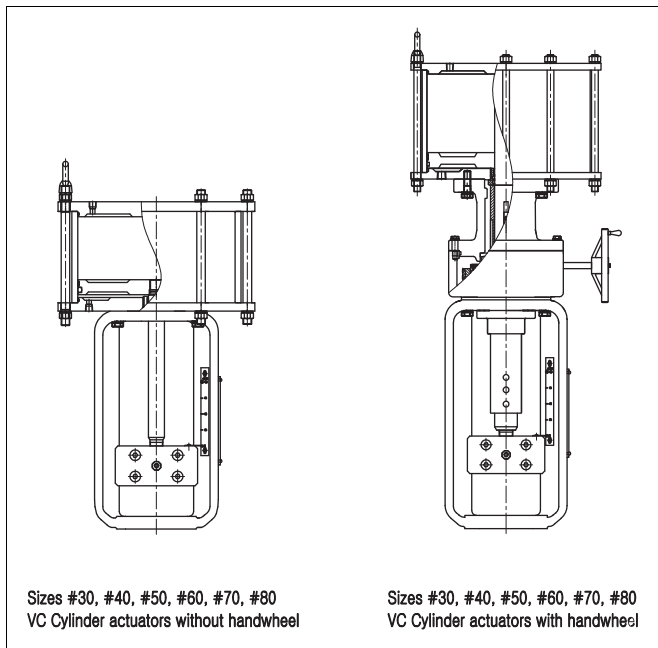

Fig. 1 VC actuator without and with the handwheel

1.3 Actuator markings

The actuator is provided with an identification plate, see Fig. 2. Identification plate markings are:

1. Type code (model)
2. Manufacturing site, date, serial no.
3. Supply, air fail to
4. Range and travel
5. Max. supply pressure

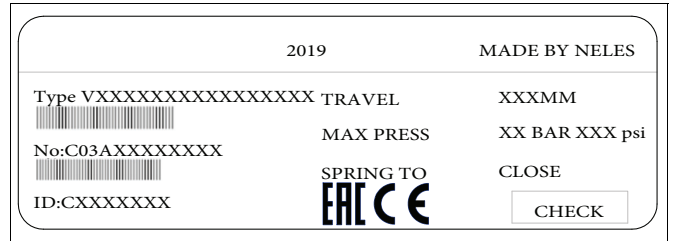

Fig. 2 Identification plate

Also, provided with an warning plate, see Fig. 3

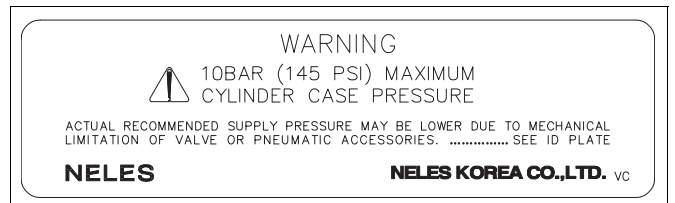

Fig. 3 Warning plate

1.4 Specifications

Table 1 VC Actuators temperature ranges

Description	Standard VC	Low. Temp. VC
Temp. range	-20 °C to 85 °C	-30 °C to 70 °C
Type code ref. (sign 6-9)	BVAK	BVLK

Note :

1. Temperature : Ambient temperature
2. Type code reference : Please see in page 13 (materials).
3. Other low temperature ranges : Please contact Neles.

Table 2 VC Actuators air supply connections

Standard	3/8" NPT for VC #30
	1/2" NPT for VC #40, #50, #60, #70 & #80
Optional	3/4" and others

Note :

1. Maximum supply pressure: 10 bar / 145 psi

Table 3 VC Actuators specifications

Actuator Size	Effect Area		Volume		Actuator Stem Size (Φ)		Maximum Stroke		Thrust at Pressure				Max. Allowable Pressure	
	cm ²	inch ²	dm ³	inch ³	mm	inch	mm	inch	Pressure		Thrust		bar	psi
									bar	psi	N	lbs		
#30	687	106	8.2	500.3	40.0	1.58	120	4.72	4.0	58	26930	6148	10.0	145
									6.0	86	40396	9116		
									8.5	121	57227	12826		
#40	1151	178	20.7	1262.0	55.0	2.17	180	7.09	4.0	58	45119	10324		
									6.0	86	67679	15308		
									8.5	121	95878	21538		
#50	1816	282	32.6	1999.4	55.0	2.17	180	7.09	4.0	58	71187	16356		
									6.0	86	106781	24252		
									8.5	121	151273	34122		
#60	2650	411	63.6	3883.9	55.0	2.17	240	9.45	4.0	58	103880	23838		
									6.0	86	155820	35346		
									8.5	121	220745	49731		
#70	3116	483	74.8	4564.4	65.0	2.56	240	9.45	4.0	58	122147	28014		
									6.0	86	183220	41538		
									8.5	121	259563	58443		
#80	4229	656	118.4	7229.1	65.0	2.56	280	11.02	4.0	58	165777	38048		
									6.0	86	248665	56416		
									8.5	121	352276	79376		

*. Note :

1. Maximum stroke : Available to extend according to the required specifications.
2. The volume is based on above maximum stroke.
3. The thrust values are not included other considerable factors.

Table 4 VC Actuators stroking time

Size	Stroke (mm)	ND Model	Stroking time(Sec.)			
			Case-1		Case-2	
			Load	Vent	Load	Vent
# 30	60	ND 9206	6	7	8	9
	80	ND 9206	8	8	10	10
	100	ND 9206	10	10	12	12
# 40	80	ND 9206	8	10	11	12
	100	ND 9206	10	11	12	13
	120	ND 9206	11	12	14	15
# 50	100	ND 9206	13	13	16	16
	120	ND 9206	15	14	18	18
	140	ND 9206	17	16	20	19
# 60	120	ND 9206	18	16	22	22
	140	ND 9206	21	19	26	24
	180	ND 9206	25	21	30	28
# 70	140	ND 9206	20	19	29	24
	180	ND 9206	24	22	34	28
	240	ND 9206	28	27	40	36
# 80	180	ND 9206	31	30	42	38
	240	ND 9206	35	31	48	42
	280	ND 9206	39	34	54	46

Note :

1. Mounted with ND 9200 smart positioners and Air set only
2. Case-1 : when applied B72G-2AS-980 Air set
Case-2 : when applied YT-200BN210 Air set
3. Air supply pressure : 6.0 barg
4. Stroking time accuracy : ± 10 %

1.5 Recycling and disposal

Most actuator parts can be recycled if sorted according to material. Most parts have material marking. A material list is supplied with the actuator. In addition, separate recycling and disposal instructions are available from the manufacturer. An actuator can also be returned to the manufacturer for recycling and disposal against a fee.

1.6 Safety precautions

CAUTION:

Don't exceed the permitted values!

Exceeding the permitted pressure value marked on the actuator may cause damage and lead to uncontrolled pressure release in the worst case. Damage to the equipment and personal injury may result.

CAUTION:

Don't dismantle a pressurized actuator!

Dismantling a pressurized actuator leads to uncontrolled pressure release. Shut off the supply pressure and release pressure from the diaphragm case before dismantling the actuator. Otherwise, personal injury and damage to equipment may result.

CAUTION:

Follow the instructions given on the actuator warning plates!

CAUTION:

Take the weight of the actuator or valve combination into account when handling it!

Do not lift the valve combination from the actuator, positioner, limit switch or their piping. Lift the actuator as directed in Section 2, lifting ropes for a valve combination should be fastened around it. The weights are shown in Section 9. Dropping may result in personal injury or damage to the equipment.

ATEX/Ex Safety

CAUTION:

Potential electrostatic charging hazard, do not rub surface with dry cloth

CAUTION:

Ensure the general process and worker protection from static electricity in the facilities.

NOTIFICATION:

The actual surface temperature of actuator is depended on the process and ambient conditions. The protection from high or low temperature must be considered by the end user before put into service.

2 TRANSPORTATION, RECEPTION AND STORAGE

Make sure that the actuator and associated equipment have not been damaged during transportation. Store the actuator carefully before installation, preferably indoors in a dry place. Do not take it to the installation site or remove the protective caps of ports for piping until just before installation.

Lift the actuator as shown in Fig. 4 in an upright from an eye bolt screwed in the place of a stop screw. Refer to Section 9 for weights.

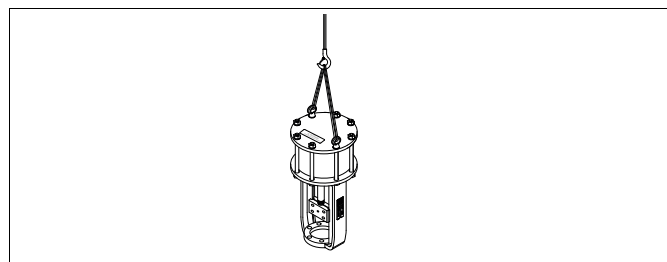

Fig. 4 Lifting the actuator.

3 MOUNTING AND REMOVAL

3.1 Actuator air supply

Dry compressed air or natural gas can be used in actuators in open-close operation, no oil spraying is needed. Clean, dry and oil-free instrument air must be used for piston actuators with a positioner. The air supply connections are presented in the dimensional drawings in Section 9. The maximum supply pressure is 10 bar.

3.2 Mounting the actuator on the valve

See Fig. 5

CAUTION:

Take the weight of the actuator or valve combination into account when handling it!

CAUTION:

Beware of the cutting movement of the valve!

Several types of Neles valves can be used with suitable clamps. Refer to the selected valve model manuals for further information on their installation, maintenance and operation.

CAUTION:

Beware of the plug movement!

Do not use air pressure higher than what specified on the identification plate.

- Mount the new or repaired actuator on top of the valve bonnet, using a suitable lifting device.
- Insert the hexagon screws and tightly fasten the yoke by turning the hexagon screws clockwise using tightening tools.
- Connect air line with actuator.
- Down the top stem (18), by using specified air pressure.
- Adjustment stem length after clamping the clamp (26) according to rated travel (stroke) as 'open' and 'close' position as per pressurizing and depressurizing the both side of cylinder

chambers (see 5.1 Adjustment for valve stem).

- Tighten the 4 socket head screws (26a) on the clamp (26) and the lower stem locknut.
- Connect accessories with actuator

CAUTION:

Avoid to turn the valve plug and stem when plug is on seat ring to prevent the seating line from being damaged.

The installation position can be selected freely, but Neles recommends installation with the upright. The actuator is thus best protected against damage due to supply air impurities or water.

When necessary, lubricate the actuator stem and guide with Cortec VCI 369 or an equivalent anti-corrosive agent to prevent it from jamming due to rust.

The actuator must not be allowed to come in contact with the pipework, because the vibrations may damage it or cause unsatisfactory operation.

3.3 Removal the actuator from the valve

CAUTION:

Make sure the valve is not pressurized when removing the actuator.

See Fig. 5.

- Shut off and disconnect the air supply lines and accessories.
- Loosen the plug stem locknut and the 4 socket head screws (26a) on the clamp (26).
- Remove the clamp (26).
- Support the actuator with the suitable lifting device.
- Remove the hexagon screws from the valve bonnet.
- Remove the actuator from the valve body assembly.

CAUTION:

Avoid to turn the valve plug and stem when plug is on seat ring to prevent the seating line from being damaged.

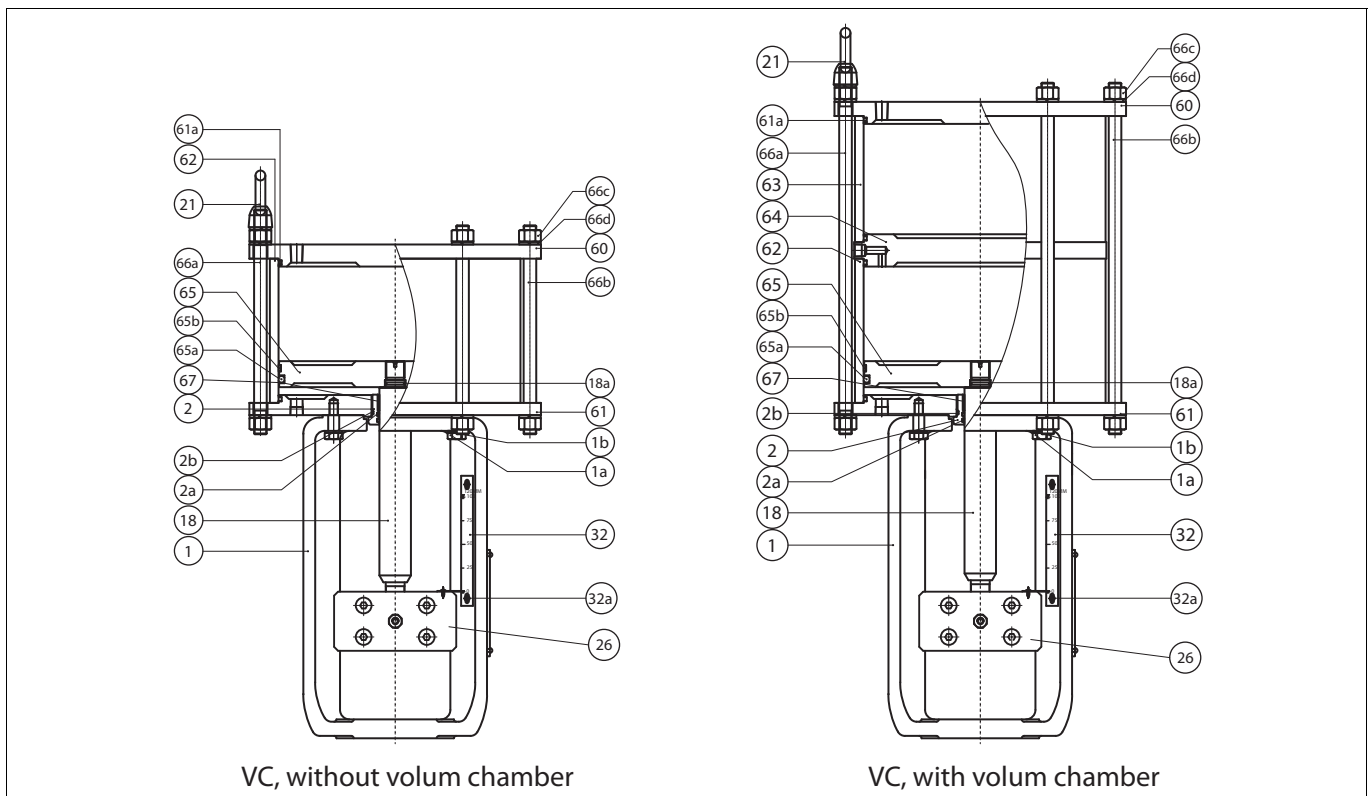

Fig. 5 VC Actuator Constructions without Handwheel (See page 7, Parts list for Fig.5)

4 MAINTENANCE

CAUTION:

Observe the safety precautions listed in Section 1.6 before starting work!

CAUTION:

When handling the actuator or the control valve assembly, take its weight into account!

4.1 General

Although the Neles VC actuators require no regular maintenance. However, check the vent port and the piston with cylinder and the stem guide for leakage. proper preventative maintenance can significantly help to prevent unplanned downtime and in real terms reduce the total cost of ownership. Neles recommends inspecting the valves at least every five (5) years. The inspection and maintenance interval depends on the actual application and process condition. The inspection and maintenance intervals can be specified together with your local Neles experts. During this periodic inspection the parts detailed in the Spare Part Set should be replaced. Time in storage should be included in the inspection interval.

Maintenance can be performed as presented below. For maintenance assistance, please contact your local Neles office. The numbers in parentheses refer to the parts lists and the exploded views of the actuator in Section 8 and in Fig. 5 & 6, unless otherwise stated.

NOTE:

When sending goods to the manufacturer for repair, do not disassemble them. Clean the valve carefully and flush the valve internals. For safety reasons, inform the manufacturer of the type of medium used in the valve (include material safety datasheets (MSDS)).

NOTE:

In order to ensure safe and effective operation, always use original spare parts to make sure that the valve functions as intended.

NOTE:

For safety reasons, replace pressure retaining bolting if the threads are damaged, have been heated, stretched or corroded.

NOTE:

If you send the actuator to the manufacturer for repair, do not dismantle it. For safety reasons, please see the warning plate on the top side of actuator.

CAUTION:

Do not dismantle the actuator or remove it from the pipeline while the valve is pressurised!

CAUTION:

Make sure the valve is not pressurized when removing the actuator.

4.2 Replacement seals for VC

We recommend that all seals be replaced when the actuator has been dismantled for servicing.

The actuator must be depressurized and the supply air pipes disconnected.

Disassembling

- Check that the actuator has been depressurized, and remove air tubing with instrument parts from the top cover (60) and bottom cover (61).

NOTE: If actuator is equipped with the handwheel, change the operation mode from 'Manual' to 'Auto' before the actuator is dismantled.

- Remove the clamp (26) after loosened the socket head screws (26a)
- Detach the actuator from valve.
- Loosened the tie rods (66a, b) and hexagon nuts (66c) and remove it.
- Pull up the top cover (60) and remove the o-rings (61a) from the o-ring groove.
- Pull up the middle plate (64) and remove the o-rings (61a) from the o-ring groove when mounted built-in volume chamber.
- Remove the chamber cylinder (63) when mounted built-in volume chamber.
- Remove the piston cylinder (62)
- Pull up and remove the piston (65) with top stem (18)
- Remove the wear ring (65b) and o-ring (65a) from the piston (65)
- Remove the hexagon screws (1a) and washers (1b) from the yoke (1) side
- Remove the stem guide (2) and o-rings (18a, 2a, 2b)
- Remove the bottom cover (61) from the yoke (1)

Cleaning and replacing

- Clean every parts
- Replace all related seal and o-rings by new one.
- Check each part whether scratched or damaged.

Reassembling

CAUTION:

Checking whether scratched on the top stem (18) and dirty particles inside of the stem guide (2) and the wear ring and o-rings before reassembling.

- Lubricate seal space (inner surface of the stem guide) and new o-rings with Unisilikon L250L or equal silicone grease
- Mount the bottom cover (61) on the yoke (1)
- Tighten the hexagon screws (1a) with washers (1b) at the yoke side
- Mount the stem guide (2) and replaced new o-rings (18a, 2a, 2b)
- Mount the piston cylinder (62)
- Mount the replaced wear ring (65b) and o-ring (65a) into piston grooves.
- Insert the piston subassembly into the center of cylinder and yoke.
- Be careful so that the threaded stem end does not scratch the inner surfaces of the stem guide (2) and o-rings
- Mount the middle plate (64) and the o-rings (61a) when mounted built-in volume chamber.
- Mount the chamber cylinder (63) and the o-rings (61a) when mounted built-in volume chamber.
- Mount the top cover (60)
- Tighten the tie rods (66a, b) and hexagon nuts (66c)
- Impress the supply pressure as per specified after reassembling. Checking leakage from assembled parts and if operation is smooth

4.3 Operation the handwheel

See Fig. 6 and Fig. 7

- Check the current valve position
- Turn the handle (46) to fit with the taper pin hole of the top stem (18) and the gear pipe (90)
- Fit and insert the taper pin (93) into the pin holes (3 holes in the top stem)
- Operation handwheel to be open or close position --- Manual mode
- Return the taper pin (93) to be unlocked with the neutral position - -- Auto mode

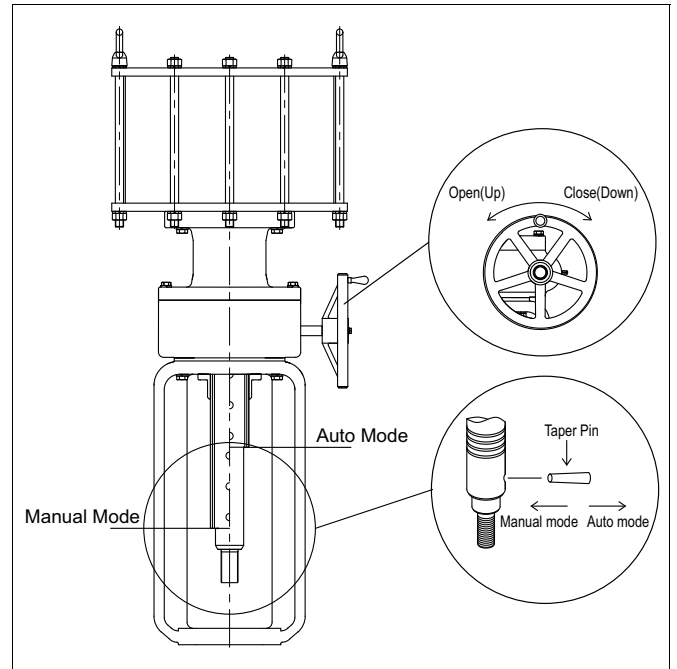

Fig. 6 VC Actuator Constructions with Handwheel

4.4 Removal the handwheel subassembly

See Fig. 5 & 6.

- Check the actuator mode should be auto mode
- Remove the hexagon screws (1a) and washers (1b) from the top of gear box cover (81)
- Remove the bottom cover (61) from the gear box cover (81)
- Remove the hexagon screws (1a) and washers (1b) from the yoke (1) side
- Remove the socket head screws (88a) from the yoke (1) side
- Remove the limiter (88) from the yoke side
- Lift up the handwheel subassembly from the yoke
- Repairing or replacing parts

CAUTION:

Keep your fingers, tools or other items out of the housing while operating the actuator with the cover open!

4.5 Adjustment for valve stem

CAUTION:

Avoid to turn the valve plug and stem when plug is on seat ring to prevent the seating line from being damaged.

See Fig. 5, 6 and 7.

- Push the valve stem and plug to be slightly touched with seat ring.
- With the handwheel or pneumatically, stroke the actuator to the fully open.
- Measure the maximum distance between the valve stem and actuator top stem (18).
- Calculate the gap (measured value - rated travel = gap).
- Move down the top stem (18) so that the distance between the valve stem and actuator top stem = gap.
- Fit the clamp (26) to align with both stems thread.
- Line up the stroke indicator (32) with the clamp indicator arrow (26b) and check actuator for operation.

Tighten the socket head screws (26a) after adjusted the rated stroke.

Table 5 VC Tightening torques for screws

PN	Description	Screw Size	Q'ty	VC Required Torques for Each Size											
				#30		#40		#50		#60		#70		#80	
				N.m	Lbf.ft	N.m	Lbf.ft	N.m	Lbf.ft	N.m	Lbf.ft	N.m	Lbf.ft	N.m	Lbf.ft
1a	Hexagon Screw (for #61, Bottom Cover)	M12 x 1.75P	8	34	25										
		M16 x 2.0P	8			65	48	65	48	65	48	65	48	65	48
21	Lifting Eye Nut (for #66a & b, Tie Rod)	M16 x 2.0P	2	65	48	65	48								
		M18 x 2.5P	2					82	61	82	61	82	61	82	61
26a	Socket Head Screw (for #26, Clamp)	M12 x 1.75P	4	34	25										
		M16 x 2.0P	4			65	48	65	48	65	48	65	48	65	48
66c	Hexagon Nut (for #66a & b, Tie Rod)	M16 x 2.0P	12	65	48										
		M16 x 2.0P	16			65	48								
		M18 x 2.5P	16					82	61						
		M18 x 2.5P	20							82	61	82	61	82	61
for VC Handwheel Screws															
18c	Socket Head Screw	M8 x 1.25P	2	26	19	26	19	26	19	26	19	26	19	26	19
46a	Hexagon Screw	M6 x 1.0P	1	20	15	20	15	20	15	20	15	20	15	20	15
80a	Hexagon Screw	M12 x 1.75P	8	34	25										
		M16 x 2.0P	8			65	48	65	48	65	48	65	48	65	48
81b	Hexagon Screw	M12 x 1.75P	8	34	25										
		M14 x 2.0P	8			50	37	50	37	50	37	50	37	50	37
82a	Socket Head Screw	M8 x 1.25P	6	26	19	26	19	26	19	26	19	26	19	26	19
86a	Socket Head Screw	M8 x 1.25P	4	26	19										
		M10 x 1.5P	4			28	21	28	21	28	21	28	21	28	21
88a	Socket Head Screw	M8 x 1.25P	4	26	19										
		M10 x 1.5P	4			28	21	28	21	28	21	28	21	28	21
94b	Hexagon Nut	M8 x 1.25P	1	26	19	26	19	26	19	26	19	26	19	26	19

Note:

1. Torque value tolerance : $\pm 10\%$
2. Torques are nominal values.

5 MALFUNCTIONS

Table 6 Possible malfunctions

Symptom	Possible cause	Action
Irregular or slow operation	Low supply pressure	Make sure that supply pressure complies with minimum thrust required by valve. Check that supply air pipes are large enough.
	Positioner fault	Check positioner operation.
	Valve fault	Check that valve functions properly without actuator.
	Incorrect actuator rating	Contact manufacturer to check rating.
	Leak in cylinder case or o-rings	Replace o-rings. See sect. 4.2 depending on actuator type.

6 TOOLS

Removal of the actuator

- Wrench set (mm)
- Hex socket wrench set
- Chisel and hammer (10 pound)
- +,- drivers

7 ORDERING SPARE PARTS

NOTE:

Always use original spare parts to make sure that the valve functions as intended.

When ordering spare parts, always include the following information:

- Type code, sales order number, serial number
- Number of the parts list, part number, name of the part and quantity required

This information can be found from the identification plate or documents.

8 EXPLODED VIEWS AND PARTS LISTS

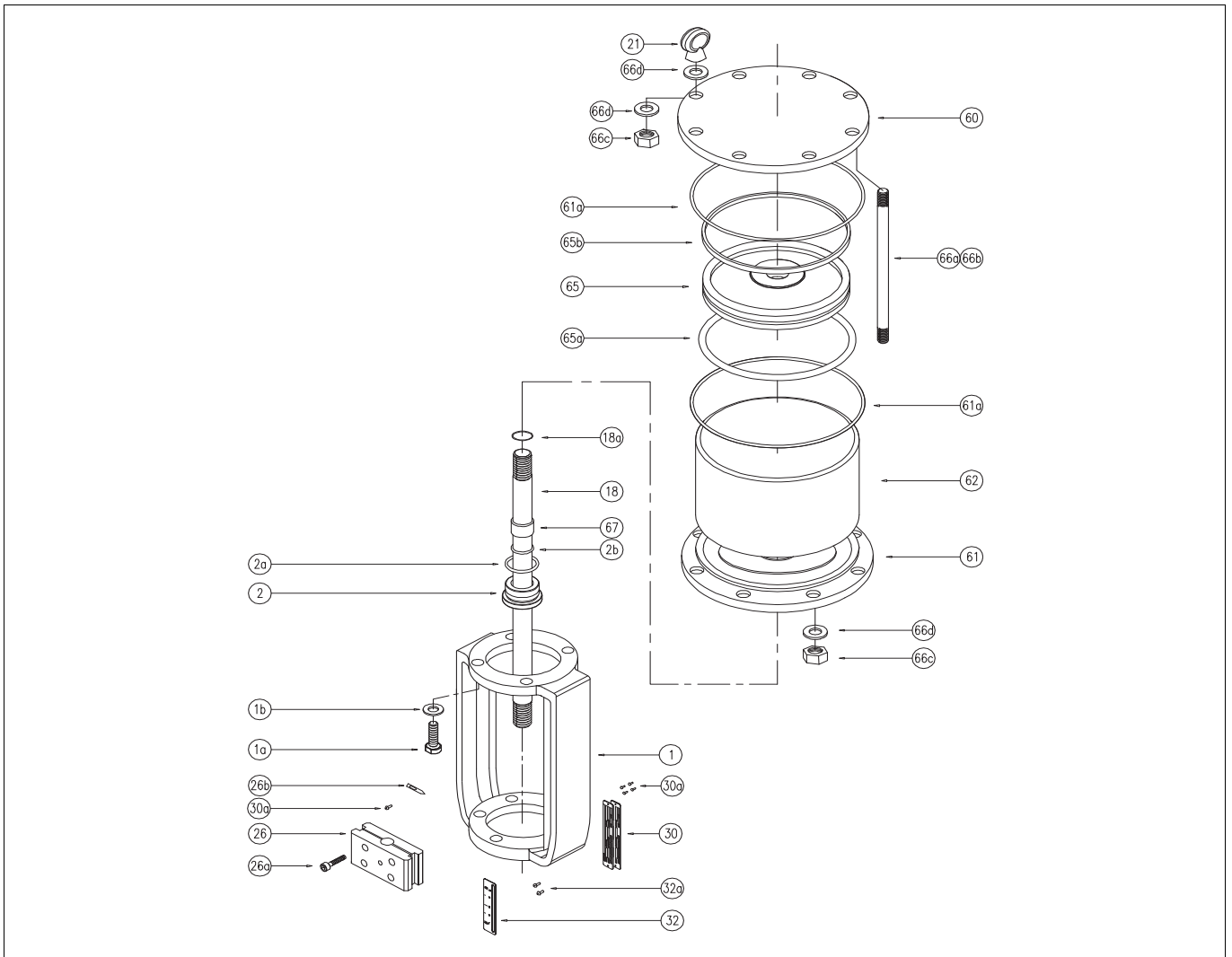

Item	Description	Recommended spare part
1	Yoke	
1a	Hexagon screw	
1b	Washer	
2	Stem guide	
2a	O-ring	x
2b	O-ring	x
18	Top stem	
18a	O-ring	x
21	Lifting eye nut	
26	Clamp	
26a	Socket head screw	
26b	Indicator arrow	
30	Identification plate	
30a	Rivet	
32	Indicator	
32a	Round head screw	
60	Top cover	
61	Bottom cover	
61a	O-ring	x
62	Piston cylinder	
63	Chamber cylinder	
64	Middle plate	
65	Piston	
65a	O-ring	x
65b	Wear ring	x
66a	Tie rod	
66b	Tie rod	
66c	Hexagon nut	
66d	Washer	
67	Du dry bearing	

9 DIMENSIONS AND WEIGHTS

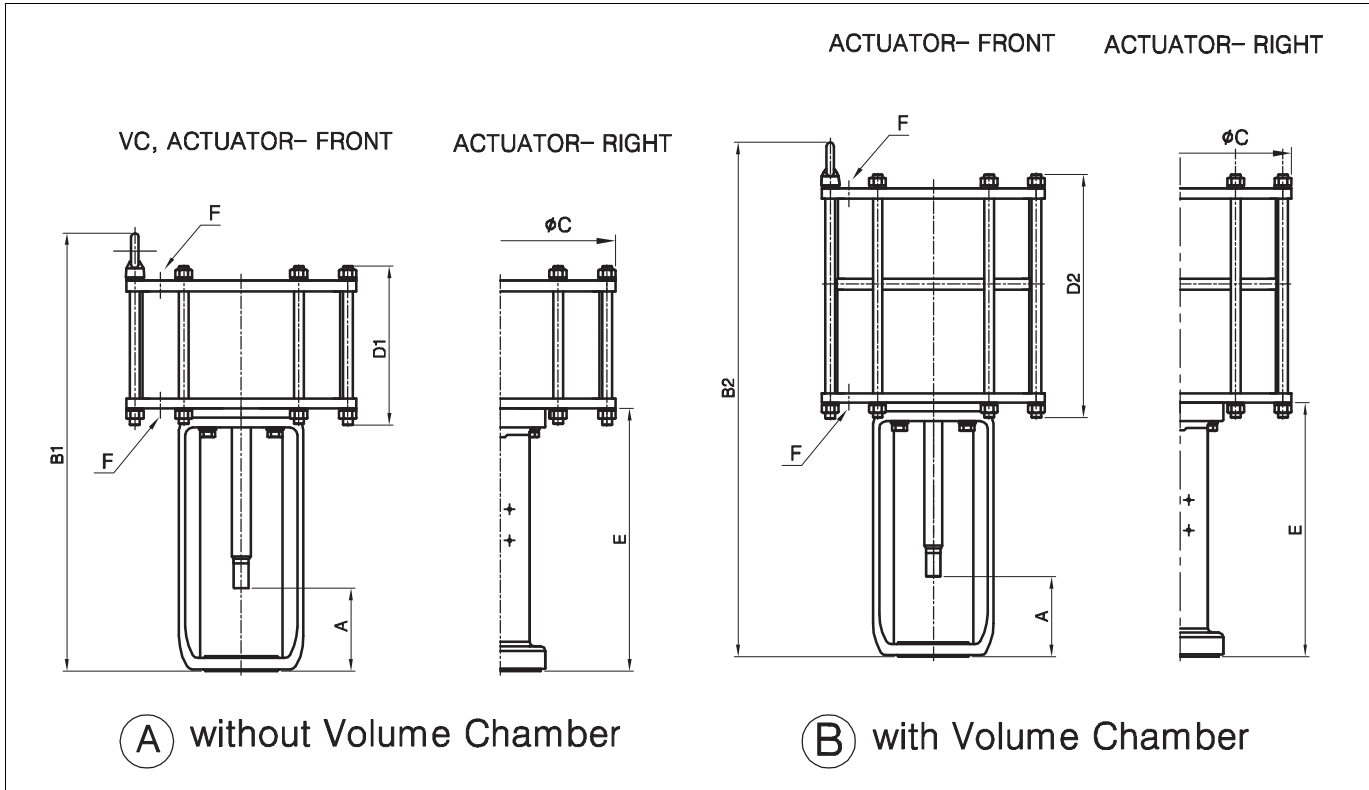

(UNIT: mm)

Size # 30								Size # 40								Size # 50										
Stroke	A	B1	ØC	D1	E	F	Weight (kg)		Stroke	A	B1	ØC	D1	E	F	Weight (kg)		Stroke	A	B1	ØC	D1	E	F	Weight (kg)	
		B2		D2			A	B			A		B			A	B			A		B				
40	145	640	Ø370	185	420	PT 1/2	92	115	40	145	810	Ø460	205	560	PT 1/2	120	148	40	145	810	Ø560	205	560	PT 1/2	186	234
		760		305							330		360													
50	145	650	Ø370	195	420	PT 1/2	94	118	50	145	820	Ø460	215	560	PT 1/2	123	152	50	145	820	Ø560	215	560	PT 1/2	189	237
		790		335							360		360													
60	145	660	Ø370	205	420	PT 1/2	97	121	60	145	830	Ø460	225	560	PT 1/2	126	155	60	145	830	Ø560	225	560	PT 1/2	192	242
		820		365							390		390													
70	145	670	Ø370	215	420	PT 1/2	100	124	70	145	840	Ø460	235	560	PT 1/2	128	159	70	145	840	Ø560	235	560	PT 1/2	195	246
		850		395							420		420													
80	145	680	Ø370	225	420	PT 1/2	103	127	80	145	850	Ø460	245	560	PT 1/2	131	162	80	145	850	Ø560	245	560	PT 1/2	198	251
		880		425							450		450													
90	145	690	Ø370	235	420	PT 1/2	106	130	90	145	860	Ø460	255	560	PT 1/2	137	166	90	145	860	Ø560	255	560	PT 1/2	201	256
		910		455							480		480													
100	145	700	Ø370	245	420	PT 1/2	108	133	100	145	870	Ø460	265	560	PT 1/2	142	177	100	145	870	Ø560	265	560	PT 1/2	203	261
		940		485							510		510													
120	145	720	Ø370	265	420	PT 1/2	114	139	120	145	890	Ø460	285	560	PT 1/2	142	177	120	145	890	Ø560	285	560	PT 1/2	209	270
		1000		545							570		570													
140	145	910	Ø460	305	560	PT 1/2	148	184	140	145	910	Ø560	305	560	PT 1/2	148	184	140	145	910	Ø560	305	560	PT 1/2	215	279
		1235		630							630		630													
180	145	950	Ø460	345	560	PT 1/2	159	198	180	145	950	Ø560	345	560	PT 1/2	159	198	180	145	950	Ø560	345	560	PT 1/2	227	298
		1355		750							750		750													

Size # 60								Size # 70								Size # 80										
Stroke	A	B1	ØC	D1	E	F	Weight (kg)		Stroke	A	B1	ØC	D1	E	F	Weight (kg)		Stroke	A	B1	ØC	D1	E	F	Weight (kg)	
		B2		D2			A	B			A		B			A	B			A		B				
100	145	954	Ø660	264	640	PT 1/2	255	344	100	145	955	Ø710	265	640	PT 3/4	322	438	100	145	954	Ø820	264	640	PT 3/4	378	519
		1199		509							510		510													
120	145	974	Ø660	284	640	PT 1/2	262	355	120	145	975	Ø710	285	640	PT 3/4	330	450	120	145	974	Ø820	284	640	PT 3/4	386	531
		1259		569							570		569													
140	145	994	Ø660	304	640	PT 1/2	269	365	140	145	995	Ø710	305	640	PT 3/4	338	461	140	145	997	Ø820	304	640	PT 3/4	394	543
		1319		629							630		629													
180	145	1034	Ø660	344	640	PT 1/2	283	386	180	145	1035	Ø710	345	640	PT 3/4	354	484	180	145	1034	Ø820	344	640	PT 3/4	410	567
		1349		749							750		749													
240	145	1094	Ø660	404	640	PT 1/2	303	417	240	145	1095	Ø710	405	640	PT 3/4	377	518	240	145	1094	Ø820	404	640	PT 3/4	435	604
		1619		929							930		929													
280	145	1134	Ø660	444	640	PT 3/4	451	628	280	145	1134	Ø820	444	640	PT 3/4	451	628	280	145	1134	Ø820	444	640	PT 3/4	451	628
		1747		1049							1049		1049													

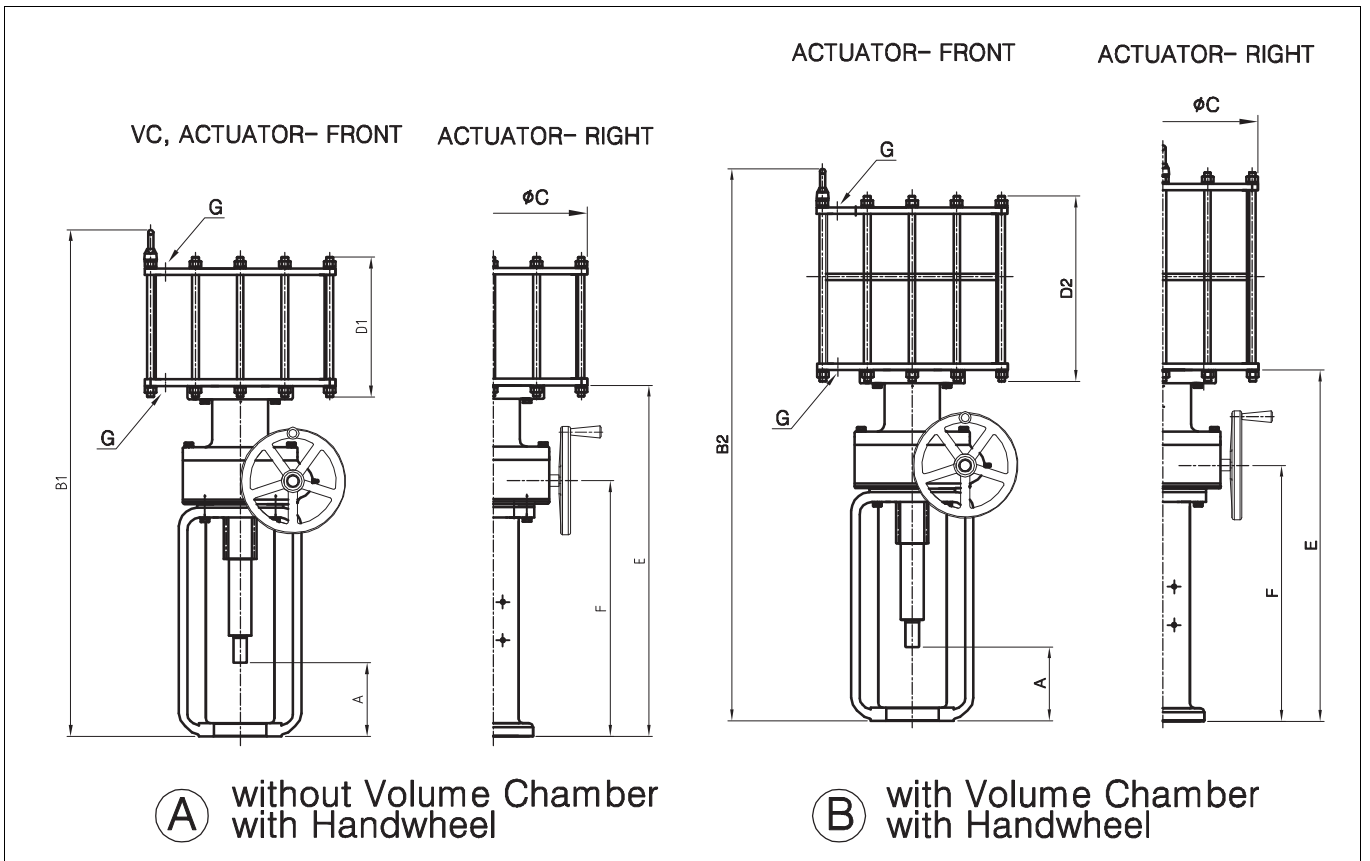

(UNIT: mm)

Size # 30										Size # 40										Size # 50									
Stroke	A	B1 B2	ØC	D1 D2	E	F	G	Weight (kg)		Stroke	A	B1 B2	ØC	D1 D2	E	F	G	Weight (kg)		Stroke	A	B1 B2	ØC	D1 D2	E	F	G	Weight (kg)	
								A	B									A	B									A	B
40	145	930 1055	Ø370	185 305	410	470	PT 1/2	134	157	40	145	1095 1220	Ø460	205 330	845	616	PT 1/2	180	208	40	145	1095 1220	Ø560	205 330	845	616	PT 1/2	246	294
50	145	940 1085	Ø370	195 335	410	470	PT 1/2	137	160	50	145	1105 1250	Ø460	215 360	845	616	PT 1/2	183	212	50	145	1105 1250	Ø560	215 360	845	616	PT 1/2	249	299
60	145	950 1115	Ø370	205 365	410	470	PT 1/2	139	163	60	145	1115 1280	Ø460	225 390	845	616	PT 1/2	186	215	60	145	1115 1280	Ø560	225 390	845	616	PT 1/2	252	303
70	145	960 1145	Ø370	215 395	410	470	PT 1/2	142	167	70	145	1125 1310	Ø460	235 420	845	616	PT 1/2	188	219	70	145	1125 1310	Ø560	235 420	845	616	PT 1/2	255	308
80	145	970 1175	Ø370	225 425	410	470	PT 1/2	144	170	80	145	1135 1340	Ø460	245 450	845	616	PT 1/2	191	222	80	145	1135 1340	Ø560	245 450	845	616	PT 1/2	258	313
90	145	980 1205	Ø370	235 455	410	470	PT 1/2	147	173	90	145	1145 1370	Ø460	255 480	845	616	PT 1/2	194	226	90	145	1145 1370	Ø560	255 480	845	616	PT 1/2	261	318
100	145	990 1235	Ø370	245 485	410	470	PT 1/2	150	176	100	145	1155 1400	Ø460	265 510	845	616	PT 1/2	197	230	100	145	1155 1400	Ø560	265 510	845	616	PT 1/2	263	322
120	145	1010 1295	Ø370	265 545	410	470	PT 1/2	155	183	120	145	1175 1460	Ø460	285 570	845	616	PT 1/2	202	237	120	145	1175 1460	Ø560	285 570	845	616	PT 1/2	269	332
										140	145	1195 1520	Ø460	305 630	845	616	PT 1/2	208	244	140	145	1195 1520	Ø560	305 630	845	616	PT 1/2	275	341
										180	145	1235 1640	Ø460	345 750	845	616	PT 1/2	219	258	180	145	1235 1640	Ø560	345 750	845	616	PT 1/2	287	360

Size # 60										Size # 70										Size # 80									
Stroke	A	B1 B2	ØC	D1 D2	E	F	G	Weight (kg)		Stroke	A	B1 B2	ØC	D1 D2	E	F	G	Weight (kg)		Stroke	A	B1 B2	ØC	D1 D2	E	F	G	Weight (kg)	
								A	B									A	B									A	B
100	145	1239 1484	Ø660	264 509	925	696	PT 1/2	315	404	100	145	1240 1488	Ø710	265 510	925	696	PT 3/4	368	502	100	145	1289 1542	Ø820	264 509	975	696	PT 3/4	438	579
120	145	1259 1544	Ø660	284 569	925	696	PT 1/2	322	415	120	145	1260 1548	Ø710	285 570	925	696	PT 3/4	376	514	120	145	1309 1602	Ø820	284 569	975	696	PT 3/4	446	591
140	145	1279 1604	Ø660	304 629	925	696	PT 1/2	329	425	140	145	1280 1608	Ø710	305 630	925	696	PT 3/4	384	525	140	145	1329 1662	Ø820	304 629	975	696	PT 3/4	454	603
180	145	1319 1724	Ø660	344 749	925	696	PT 1/2	343	446	180	145	1320 1728	Ø710	345 750	925	696	PT 3/4	400	548	180	145	1369 1782	Ø820	344 749	975	696	PT 3/4	470	627
240	145	1379 1904	Ø660	404 929	925	696	PT 1/2	363	477	240	145	1380 1908	Ø710	405 930	925	696	PT 3/4	423	582	240	145	1429 1962	Ø820	404 929	975	696	PT 3/4	495	664
																				280	145	1469 2082	Ø820	444 1049	975	696	PT 3/4	511	688

10 TYPE CODE

Pneumatic Cylinder Actuator, Linear type, Series VC

1.	2.	3.	4.	5.	6.	7.	8.	9.	10.	11.	12.	13.	14.
VC	C	30	X	080	B	V	A	K	X	X	B	V	-

ACTUATOR CONSTRUCTIONS

1.	ACTUATOR SERIES
VC	Pneumatic Cylinder actuator, Linear type

2.	FUNCTION CODE
C	Double Acting (Springless)
Y	Special

3.	ACTUATOR SIZE
	Outline Dimension
30	Ø370 mm
40	Ø460 mm
50	Ø560 mm
	Optional Actuator Size
60	Ø660 mm
70	Ø710 mm
80	Ø820 mm
YY	Special

4.	SPRING RANGE
X	Not Applicable
Y	Special

5.	STROKE						
	VC_30	VC_40	VC_50	Optional Size and Stroke	VC_60	VC_70	VC_80
040	0	0	0		0	0	0
050	0	0	0		0	0	0
060	0	0	0		0	0	0
070	0	0	0		0	0	0
080	0	0	0		0	0	0
090	0	0	0		0	0	0
100	0	0	0		0	0	0
120	0	0	0		0	0	0
140	-	0	0		0	0	0
180	-	0	0		0	0	0
240	-	-	-		0	0	0
280	-	-	-	-	-	0	
YYY	Contact Neles for special stroke						

MATERIALS

6.	ACTUATOR CASE MATERIAL
B	JIS G3101-SS400 (ASTM A-36)
Y	Special

7.	PISTON MATERIAL
V	ASTM B209 ALLOY 6061 T6
Y	Special

8.	SEAL MATERIAL
A	Nitrile rubber
	Optional Seal Application
L	Low temp. NBR
S	Low temp. Silicone
Y	Special

9.	BOLTING MATERIAL
K	Stainless steel
Y	Special

OTHERS

10.	POSITION LIMITATION
X	Not applicable
	Optional Application
M	Mechanical Stopper
Y	Special

11.	EXTERNAL OVERRIDE OPTION
X	Not Applicable
A	Handwheel
Y	Special mounting side or Special H/W construction

12.	AIR SUPPLY CONNECTION	
	Connection Size	Actuator Size
B	3/8" NPT	VC_30
C	1/2" NPT	VC_40/50/60/70/80
	Optional Air Supply Connection	
D	3/4" NPT	
Y	Special	

13.	OPTIONS
X	Not Applicable
V	Volume Chamber
Y	Special

14.	ACTUATOR DESIGN APPLICATION
-	Original type

Valmet Flow Control Oy

Vanha Porvoontie 229, 01380 Vantaa, Finland.

Tel. +358 10 417 5000.

www.valmet.com/flowcontrol

Subject to change without prior notice.

Neles, Neles Easyflow, Jamesbury, Stonel, Valvcon and Flowrox, and certain other trademarks, are either registered trademarks or trademarks of Valmet Oyj or its subsidiaries in the United States and/or in other countries.

For more information www.neles.com/trademarks

