

Neles™ Omega™ globe valve

Series GM

Installation, maintenance and
operating instructions

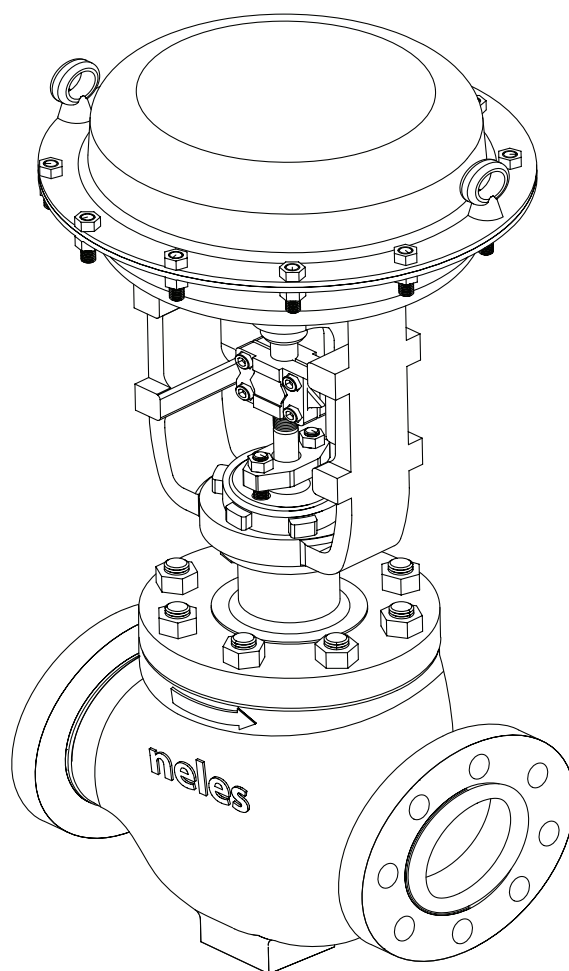

Table of contents

GENERAL	3	TESTING THE VALVE	10
Scope of the manual	3	REMOVAL & MOUNTING THE ACTUATOR	11
Valve construction	3	TOOLS	12
Valve markings	3	ORDERING SPARE PARTS	12
Technical specifications	3	EXPLODED VIEW AND PARTS LIST	13
Valve seat leakage class	3	DIMENSIONS AND WEIGHTS	14
Recycling and disposal	3	Valve GM	14
Safety precautions	4	Actuator VDD/VDR	16
TRANSPORTATION, RECEPTION AND STORAGE	4	Actuator VBD/R	18
VALVE INSTALLATION	4	Actuator VBC	19
General	4	Actuator VBC with volume chamber	20
Installation into the pipeline	5	Actuator VCC without handwheel	21
Hydrostatic testing and Line flushing	5	Actuator VCC with handwheel	22
Control valve assembly	5	TYPE CODE	23
Valve insulation	5		
MAINTENANCE	5		
General	6		
Gland packing adjustment & bellows seal	6		
Replacing the gland packing	6		
Replacing the general trim and body reassembly	7		
Pilot balanced plug	8		
Pilot balanced plug	9		

Subject to change without notice.

All trademarks are property of their respective owners.



This product meets the requirements set by the Customs Union of the Republic of Belarus, the Republic of Kazakhstan and the Russian Federation.

READ THESE INSTRUCTIONS FIRST!

These instructions provide information about safe handling and operation of the valve.

If you require additional assistance, please contact the manufacturer or manufacturer's representative.

SAVE THESE INSTRUCTIONS!

Addresses and phone numbers are printed on the back cover.

1. GENERAL

1.1 Scope of the manual

This manual provides essential information on series GM-Omega multistage trim installed sliding stem valves. Actuators and positioners are only discussed briefly. Refer to the individual manuals for further information on their installation, operation and maintenance.

NOTE:

Selection and use of the valve in a specific application requires close consideration of detailed aspects. Due to the nature of the product, this manual cannot cover all the individual situations that may occur when the valve is used.

If you are uncertain about use of the valve or its suitability for your intended purpose, please contact Valmet for more information.

For valves in oxygen service, please see also the separate installation, maintenance and operating instructions for oxygen service (see Neles document id:10O270EN.pdf).

1.2 Valve construction

Series GM-Omega multistage trim valves are flanged (weld end available) single seated sliding stem control valves. The valve seat ring and retainer and plug with stem is a module accessible through the bonnet opening (top entry) of the body.

Our standard design provides a cage guide with a piston type plug with a quick change seat ring. The two split cages (cage guide and multistage cage) and inserted plug seal ring makes strong support to ensure valve alignment.

For few cases in very small rated Cv, a unbalanced contoured trim is used in this series.

This series is available with series of reduced Cv trims and the standard seat tightness is class III-IV, optional trims can meet to class V, ANSI/FCI 70-2.

The detailed structure is revealed by the type code shown on the valve identification plate. The type code is explained in Section 11.

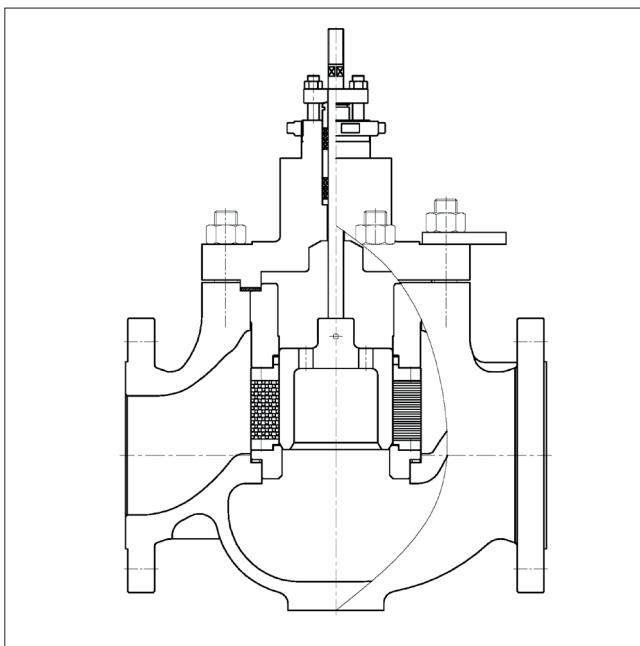

Fig. 1 Construction of the Neles GM series Single Seated Valve

1.3 Valve markings

The body markings are: manufacturer's trademark, nominal size, pressure rating and material of the body. The identification plate is attached on an actuator yoke side.

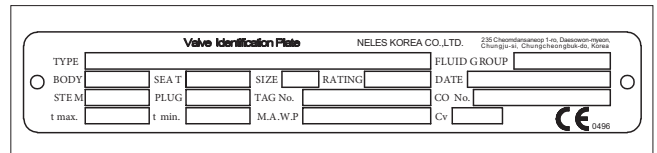

Fig. 2 Identification (name) plate example

Markings on the identification plate:

1. Type designation (Valve code)
2. Size, Rating
3. Cv
4. Body material
5. Plug, Stem material
6. Seat material
7. Temp. min./max.
8. Maximum (shut-off) pressure
9. Valve manufacturing date
10. Tag No.
11. CO No.

1.4 Technical specifications

Face-to-face length: ANSI/ISA-75.08.01, 03, 05 & ANSI/ISA-75.08.06 (Long)

Body rating: Class 150 to Class 2500
PN 10 to PN 450

Max. pressure differential: acc. to pressure class

Temperature range: -196° to +593 °C (depending on the body materials and bonnet type)

Flow direction: indicated by an arrow on the body (normally flow to open)

Actuator mounting: threaded bonnet with yoke nut or bolted yoke

Stem connection: clamp with bolts/nuts

Dimensions: see Section 10

Weights: see Section 10

Note that the max. shut-off pressure is based on the mechanical maximum differential pressure at ambient temperature. You must always observe the fluid temperature when deciding on applicable pressure values. When selecting a valve you must also check the noise level, cavitation intensity, flow velocity, actuator load factor, etc. using Nelprof.

1.5 Valve seat leakage class

The valve follows the seat leakage classifications of ANSI/FCI 70-2 requirement.

1.6 Recycling and disposal

Most valve parts can be recycled if sorted according to material. Most parts have a material marking. A material list is supplied with the valve. In addition, separate recycling and disposal instructions are available from the manufacturer. A valve can also be returned to the manufacturer for recycling and disposal for a fee.

1.7 Safety precautions

CAUTION:

Do not exceed the valve performance limitations!

Exceeding the limitations marked on the valve may cause damage and lead to uncontrolled pressure release. Damage or personal injury may result

CAUTION:

Do not dismantle the valve or remove it from the pipeline while the valve is pressurised!

Dismantling or removing a pressurised valve will result in uncontrolled pressure release. Always isolate the relevant part of the pipeline, release the pressure from the valve and remove the medium before dismantling the valve.

Be aware of the type of medium involved. Protect yourself and the environment from any harmful or poisonous substances. Make sure that no medium can enter the pipeline during valve maintenance.

Failure to do this may result in damage or personal injury.

CAUTION:

Beware of the plug movement!

Keep fingers, other parts of the body, tools and other objects out of the open flow port. Leave no foreign objects inside the pipeline. When the valve is actuated, the plug functions as a cutting device. Close and detach the actuator pressure supply pipeline for valve maintenance. Failure to do this may result in damage or personal injury.

CAUTION:

Protect yourself from noise!

The valve may produce noise in the pipeline. The noise level depends on the application. It can be measured or calculated using the Neles Nelprof software. Observe the relevant working environment regulations in terms of noise emission.

CAUTION:

Beware of a very cold or hot valve!

The valve body may be very cold or very hot during use. Protect yourself against cold injuries or burns.

CAUTION:

When handling the valve or the control valve assembly, take its weight into account!

Never lift the valve or control valve assembly by the positioner, the limit switch or their piping.

Place the lifting ropes securely around the valve body (see Fig. 3). Damage or personal injury may result from falling parts.

CAUTION:

Follow the proper procedures when handling and servicing Oxygen valves.

CAUTION:

Hexavalent chromium(VI) or Cr(VI), is known to cause cancer. Be sure to use all appropriate personal protective equipment (PPE) when welding metals containing chromium.

CAUTION:

Ensure that any weld splatter does not fall onto the valve trim. This may prevent proper trim movement or damage critical seating surfaces causing leaks.

CAUTION:

Make sure the valve is not pressurized when removing the actuator.

CAUTION:

Potential electrostatic charging hazard. Ensure the protection in the process.

2. TRANSPORTATION, RECEPTION AND STORAGE

Check the valve and the accompanying devices for any damage that may have occurred during transport.

The valve is delivered in the closed position. A valve equipped with a spring-return actuator is delivered in the position determined by the spring.

Store the valve carefully before installation, preferably indoors in a dry place.

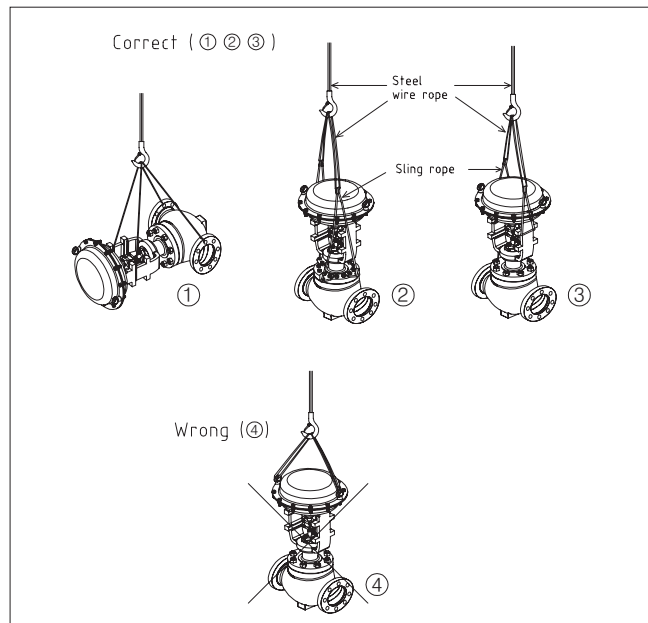

Fig. 3 Lifting the valve

Do not remove the flow port protectors until immediately before installation of the valve into the pipeline.

3. VALVE INSTALLATION

3.1 General

Remove the flow port protectors and check that the valve is clean inside.

CAUTION:

When handling the valve or the control valve assembly, take its weight into account!

NOTE:

Heat insulation should be installed when valve design temperature is over 260°C to protect actuator, positioner and accessories from heat.

3.2 Installation into the pipeline

Pipeline cleaning

Make sure no foreign particles, such as sand or pieces of welding electrode, are in the pipeline, they may damage the sealing surfaces.

Installation valve

The valve has an arrow indicating the flow direction. Install the valve in the pipeline so that the flow direction of the valve corresponds to the flow direction marked on the pipe.

The mounting orientation of the valve should be vertical position as it is shown on Fig.4.

CAUTION:

Hexavalent chromium(VI) or Cr(VI), is known to cause cancer. Be sure to use all appropriate personal protective equipment (PPE) when welding metals containing chromium.

CAUTION:

Ensure that any weld splatter does not fall onto the valve trim. This may prevent proper trim movement or damage critical seating surfaces causing leaks.

NOTE:

For any other mounting position, please consult the factory.

Choose flange gaskets according to the operating conditions.

Do not attempt to correct a pipeline misalignment by means of flange bolting.

Loads on the valve body from pipeline vibrations can be reduced by supporting the pipeline properly. Reduced vibration also increases the lifetime of the positioner.

Where necessary, you can support the valve by the body, using regular pipe clamps and supports. Do not fasten supports to the valve or flange bolting or to the actuator, see Fig. 4.

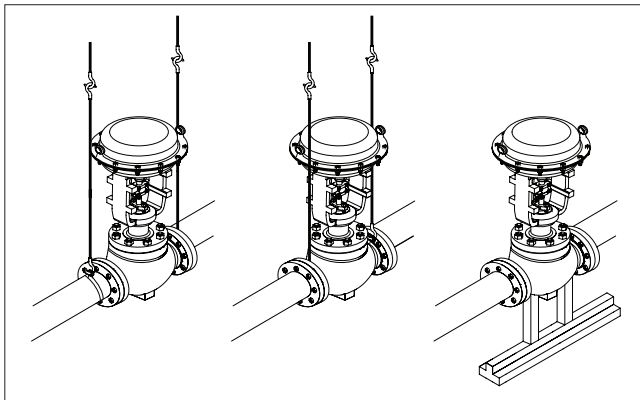

Fig. 4 Installing the control valve into pipeline using supports

3.3 Hydrostatic testing and Line flushing

When the line is hydrostatic test and flushing, the control valve should not used as an isolating valve. Make sure the control valve always be opened position before start this process. Otherwise valve and trim damage or failure of the seals could result.

Flushing and hydrostatic test kit can be purchased from Valmet.

CAUTION:

Flushing trim kit should be installed in the valve (especially 'Omega trim' application) to protect the original trim and the flow passages while the valve installation and line flushing.

Unless this caution could result in clogging trim, low flow rates, unstable control, valve leakage and excessive noise and other trouble.

3.4 Control valve assembly

Check all joints, piping and cables.

Check that the actuator stop screws, positioner and limit switches are calibrated. Refer to their installation, maintenance and operating manuals.

3.5 Valve insulation

If necessary, the valve may be insulated. Insulation must not continue above the upper level of the valve body, see Fig. 5.

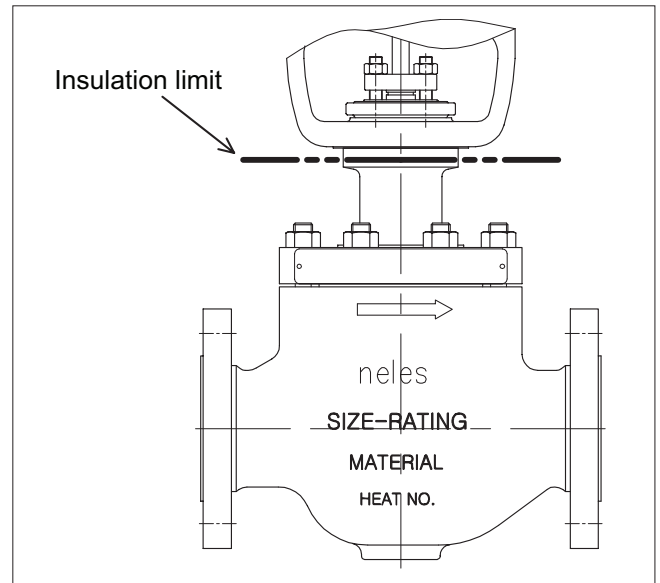

Fig. 5 Insulation of the valve

4. MAINTENANCE

CAUTION:

Observe the safety precautions listed in Section 1.7 before starting work!

CAUTION:

When handling the valve or the control valve assembly, take its weight into account!

4.1 General

The Neles series GM-Omega multistage trim valves require no regular maintenance. However, check the gland packing for leakage. This section outlines the maintenance that can be carried out by the user.

The numbers in parentheses refer to the parts lists and the exploded views of the valve in Section 9.

NOTE:

If you send the valve to the manufacturer for repair, do not dismantle it. Clean the valve carefully, including the inside. For safety reasons, inform the manufacturer of the nature of the medium when you send the valve.

NOTE:

Always use original spare parts to make sure the valve functions as intended.

4.2 Gland packing adjustment & bellows seal

In the event of a packing leakage tighten the hexagon nuts (18) in ¼ turn steps each until the leakage is stopped. Do not tighten more than necessary.

NOTE:

In case of the bellows seal bonnet construction, the gland packings are installed up at the top of the bellows bonnet(8L).

CAUTION:

Bellows assembly(8M) is welded with a the plug set. The bellows assembly should not be twisted.

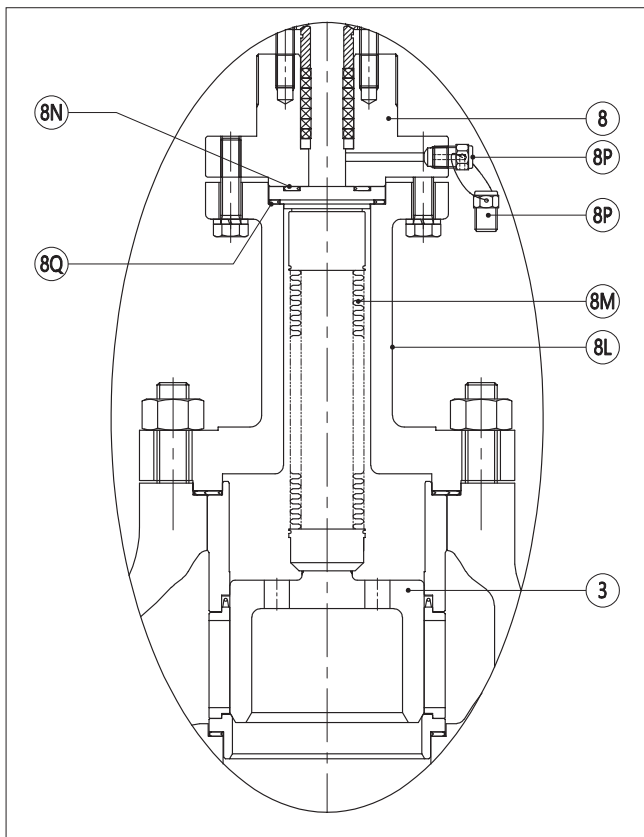

Fig. 6 Bellows seal construction

4.3 Replacing the gland packing

CAUTION:

Bellows seal valve is shipped from the factory with a vent plug (8P) installed on the test connector. If there is any damage to the bellows, or external leakage occurred then replace the vent plug (8P) with an additional blind plug (8P) hanging. So that the fluid does not leak to the out side.

CAUTION:

Do not dismantle the valve or remove it from the pipeline while the valve is pressurised!

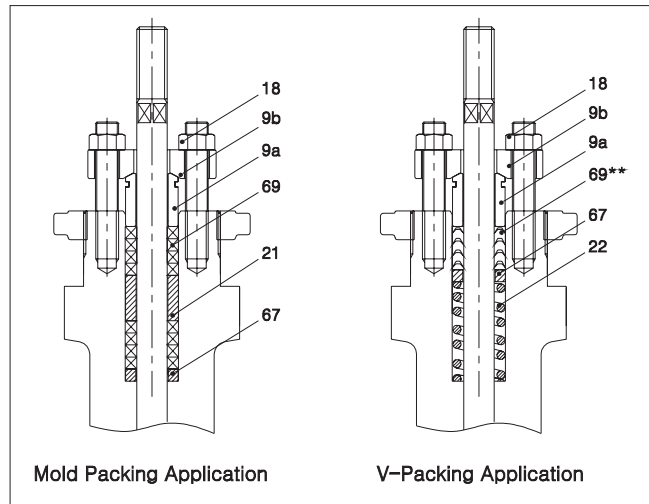

Fig. 7 Gland packing

- Make sure the valve is not pressurised.
- Remove the actuator from the valve stem according to the instructions given in the actuator manual.
- Loosen and remove the hexagon nuts (18).
- Remove the gland flange (9b), and gland (9a) up to the valve stem.
- Remove the old packing rings (69) using a pointed tool, avoid damaging the seal surfaces and valve stem.
- Clean the packing ring counterbore.
- Mount the new packing rings one by one into the packing gland box using the gland as a tool and mount the gland with hand-tightened nuts.
- Each packing ring (69) shall be firmly seated into the stuffing box using the packing tamping tool.

CAUTION:

Be careful when using a hammer.

- Joints of successive braided type packing rings (69& 69a if applicable) must be inserted 180 degrees against the previously inserted packing rings (69 & 69a if applicable)
- Apply lubricant suitable for process temperature to inner surface of all the packing rings except PTFE packing and emission packing. (69) (& 69a if applicable)
- Apply lubricant suitable for process temperature to the gland studs (14) and nuts (18) properly
- Fasten the gland with the hexagon nut (18) and tighten them.
- Check leakage when the valve is pressurised.

4.4 Replacing the general trim and body reassembly

NOTE:

The general trim set consists of the seat ring , valve plug and stem, disk stack, cage guide, seal ring and gaskets (for seat and body).

The high temperature trim set consists of the seat, plug and stem, one-piece disk stack cage, 3 seal rings and gaskets (for seat and body). Please refer to chapter 4.6

- Make sure the valve is not pressurised.
- Remove the actuator from the valve stem according to the instructions given in the actuator manual and next Section 6.
- Remove the hexagon nuts (18) slightly.
- Remove the hexagon nuts (17).
- Remove the bonnet (8)
- Remove the stem and plug (5 & 3).
- Remove the cage guide (16), disk stack (25) and the seal ring (64). Avoid from damaging the seal ring between the disk stack and cage guide.
- Remove the bonnet gasket (65), seat ring (7), seat gasket (63)

Table 1 Required torques for bonnet nuts

Valve Size		Rating (ANSI)	Bonnet Stud Bolts		Required Torques (±5% allowable)		
mm	in		Size	Q'ty	Nm	lbf ft	
25	1	150-300	1/2"-13UNC	4	45	33	
			600	1/2"-13UNC	4	45	33
			900	3/4"-10UNC	8	160	118
			1500	3/4"-10UNC	8	160	118
			2500	3/4"-10UNC	8	160	118
40	1,5	150-300	1/2"-13UNC	4	45	33	
			600	1/2"-13UNC	4	45	33
			900	7/8"-9UNC	8	140	103
			1500	7/8"-9UNC	8	140	103
			2500	7/8"-9UNC	8	140	103
50	2	150-300	1/2"-13UNC	8	45	33	
			600	9/16"-12UNC	8	65	48
			900	7/8"-9UNC	8	140	103
			1500	7/8"-9UNC	8	140	103
			2500	7/8"-9UNC	8	140	103
75	3	150-300	5/8"-11UNC	8	90	66	
			600	5/8"-11UNC	10	90	66
			900	7/8"-9UNC	8	250	184
			1500	1-1/8"-8UN	8	300	221
			2500	1-1/4"-8UN	8	400	295
100	4	150-300	3/4"-10UNC	8	160	118	
			600	3/4"-10UNC	10	160	118
			900	1-1/8"-8UN	8	560	413
			1500	1-1/8"-8UN	8	560	413
			2500	1-1/2"-8UN	8	1400	1033
150	6	150-300	3/4"-10UNC	12	160	118	
			600	7/8"-9UNC	12	250	184
			900	1-1/8"-8UN	12	560	413
			1500	1-3/8"-8UN	12	800	590
			2500	1-1/2"-8UN	12	1400	1033
200	8	150-300	7/8"-9UNC	12	250	184	
			600	1"-8UNC	12	380	280
			900	1-3/8"-8UN	12	1100	811
			1500	1-5/8"-8UNC	12	1200	885
250	10	150-300	1"-8UNC	16	380	280	
			600	1"-8UNC	16	380	280
			900	1-3/8"-8UN	12	1100	811
			1500	1-3/4"-8UN	12	1200	885
300	12	150-300	1-1/8"-8UN	16	560	413	
			600	1-1/8"-8UN	16	560	413
			900	1-3/8"-8UN	20	1100	811
			2500	2-3/4"-8UNC	12	3500	2581
350	14	150-300	1-1/4"-8UN	16	790	583	
			600	1-1/4"-8UN	16	790	583
			900	1-1/2"-8UN	20	1400	1033
400	16	150-300	1-1/4"-8UN	20	790	583	
			600	1-3/8"-8UN	20	1100	811
			900	1-5/8"-8UNC	20	1200	885
			1500	2-1/2"-8UNC	12	3000	2213

Table 2 Required torques for packing nuts

Packing Type	Stem Size mm	Rating (ANSI)	Required Torques (±5% allowable)	
			Min. Nm(lbf ft)	Max. Nm(lbf ft)
Graphite & PTFE Carbon Fiber packing	Ø12.7	150-300	5 (4)	7 (5)
			6 (4)	8 (6)
			7 (5)	10 (7)
			9 (7)	12 (9)
			10 (7)	14 (10)
	Ø19.05	150-300	11 (8)	16 (12)
			14 (10)	19 (14)
			17 (12)	23 (17)
			19 (14)	27 (20)
			22 (16)	21 (15)
	Ø25.4	150-300	18 (13)	25 (18)
			23 (17)	32 (24)
			27 (20)	38 (28)
			32 (24)	44 (32)
			36 (27)	51 (38)
Ø36	150-300	26 (19)	36 (27)	
		32 (24)	45 (33)	
		39 (29)	54 (40)	
		45 (33)	64 (47)	
		52 (38)	73 (54)	
V-ring packing (PTFE)	Ø12.7	150-300	3 (2)	5 (4)
			4 (3)	6 (4)
			5 (4)	7 (5)
			6 (4)	8 (5)
			7 (5)	10 (7)
	Ø19.05	150-300	8 (6)	11 (8)
			10 (7)	14 (10)
			12 (9)	16 (12)
			14 (10)	19 (14)
			16 (12)	22 (16)
	Ø25.4	150-300	13 (10)	18 (13)
			16 (12)	22 (16)
			19 (14)	27 (20)
			22 (16)	31 (23)
			25 (18)	35 (26)
Ø36	150-300	18 (13)	25 (18)	
		23 (17)	32 (24)	
		27 (20)	38 (28)	
		32 (24)	44 (32)	
		36 (27)	51 (38)	

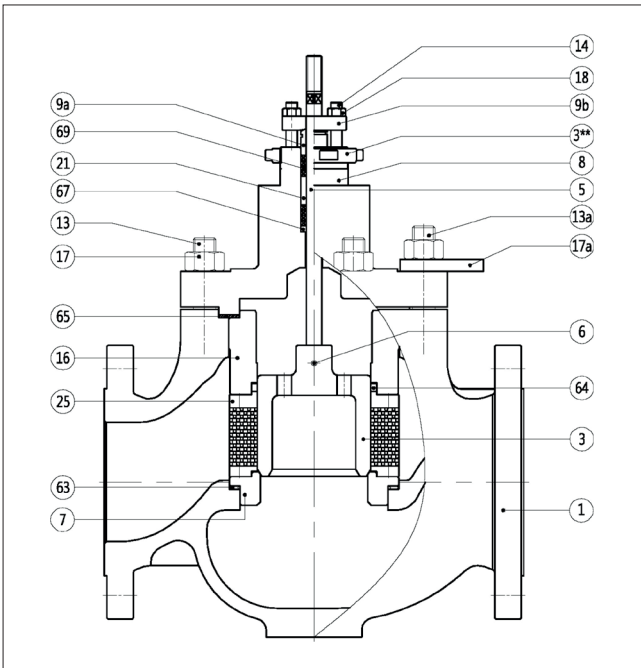

Fig. 8 Conventional Omega-Balanced Trim

CAUTION:

Do not reuse the spiral wound gaskets (63 & 65), this is need to be replace each time the valve is disassembled.

- Remove the hexagon nuts (18), gland flange (9b) and gland (9a)
- Remove the old packing rings (69)

NOTE:

If the valve have excess leakage, the plug and seating surface need lapping and cleaning.

NOTE:

'Omega' multistage Cage Cleaning

The welded 'Omega' multistage cage is not available disassembling, make sure the ultrasonic cleaning in the frequency range of 250 ~ 400 kHz and Min. duration 60 min.

- Clean the body gasket surface.
- Insert a new seat gasket (63) and the seat ring (7) into the body.
- Install the disk stack (25), seal ring (64), cage guide (16) and plug stem assembly (3, 5, 6) very carefully.
- Insert the body gasket (65).
- Mount the bonnet on the body carefully maintaining alignment with the plug and the stem and with the disk stack in the closed position, so that the arrow on the body and on the bonnet point in the same direction.
- Apply lubricant suitable for process temperature to the studs(13), gland studs (14), hexagon nuts(17), nuts (18), stem(5) thread area properly.
- Insert the hexagon nuts (17) into stud (13) and slightly fasten the nuts.

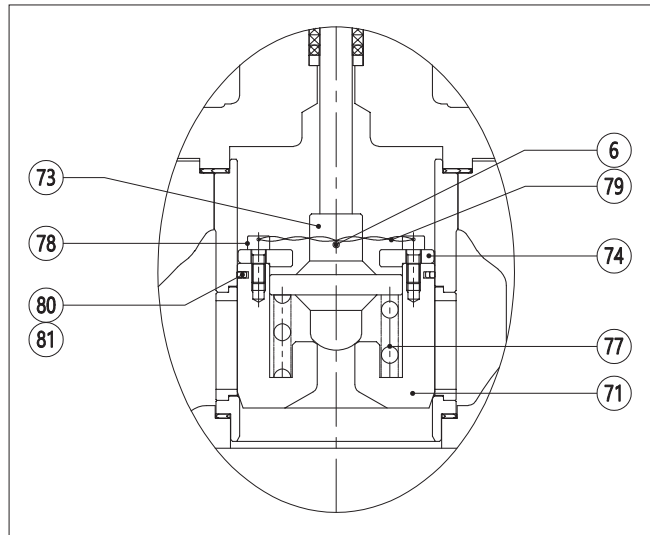

Fig. 9 Pilot balanced Trim

CAUTION:

Do not strongly tighten stud nuts at this time.

- Insert the packing rings (69) according to above 4.3

CAUTION:

The all related parts (seat ring, disk stack, plug & stem, bonnet) must be properly aligned in the body.

- Tighten hexagon nuts (17) until plug and seat contact is obtained with proper bolt torque.

4.5 Pilot balanced plug

Disassembly & Assembly

- Mount the plug and stem assembly on the chuck to setting. Compress the stem by the lathe center for release (reduce) the spring tension.
- Remove the pilot wire (76).
- Remove the pilot bolts (75).

CAUTION:

When opening the pilot plug bolts (75), first loosen them all before completely removing the first bolt. There is a spring inside the pilot, so be careful of the release of the spring tension when removing the pilot plug bolts.

- Remove the pilot cover (74).
- Remove the pilot plug (73) and stem (5) from pilot main plug (71).
- Remove the pilot spring (77) carefully.
- Remove the pilot plug (73) and the pilot seat as well as the surface inside of the pilot main plug (71). If there is damage, scratches or grooves, it should be replaced or repaired.
- Insert the cleaned pilot spring (77) into the upper side of main plug.
- Install the pilot plug (73) & stem (5) on the spring (77).
- Install the pilot cover (74) and fasten the pilot bolts (75) keep in balance.
- Install wire (76) for connecting the all pilot bolts due to prevent loose on operation.

4.6 Pilot balanced plug

Disassembly & Assembly

CAUTION:

Disassemble the graphite seal from the cage and plug and stem assembly when the sticking issue or weird noise happens during the valve operation in normal process condition. If not happen, then no need to disassemble the graphite seal.

- Mount the cage (15), plug and stem assembly (5) on the chuck horizontally.
- Pull out the plug and stem assembly (5) from the cage (15) by hammering on bottom surface of plug.
- Remove the graphite seal (64) from plug groove one by one.

CAUTION:

Plug and stem assembly will be separated from the cage when 3 sets of graphite seal are out.

- Inspect the cage (15), plug and stem assembly (5) and seat ring (7).
- If there is damage, scratches on grooves, it should be replaced or repaired.
- Mount the half of new graphite seal (64) on the chuck.
- Grab the graphite seal (64) by both hands, and push and cut it into the two pieces.
- Repeat to cut the other seal in order to prepare 3 sets of graphite seal.
- Mount the cage (15) on the chuck (or similar instrument) vertically so that the plug and stem assembly (5) can be inserted from up to down.
- Make to align the position of plug and stem assembly (5) in order to insert it to the inside of cage.
- Insert each graphite seal (64) to the plug groove one by one.
- Hammering the stem ends carefully in order to insert the graphite plug seal (64) without the damage.

CAUTION:

When insert each graphite seal to the plug groove, do not mix the cut graphite seal ring each other.

CAUTION:

Make the cut surfaces of graphite seal perfectly fits each other during the inserting to the plug groove.

CAUTION:

Make the graphite plug seal will not be out of groove during the inserting by hammering.

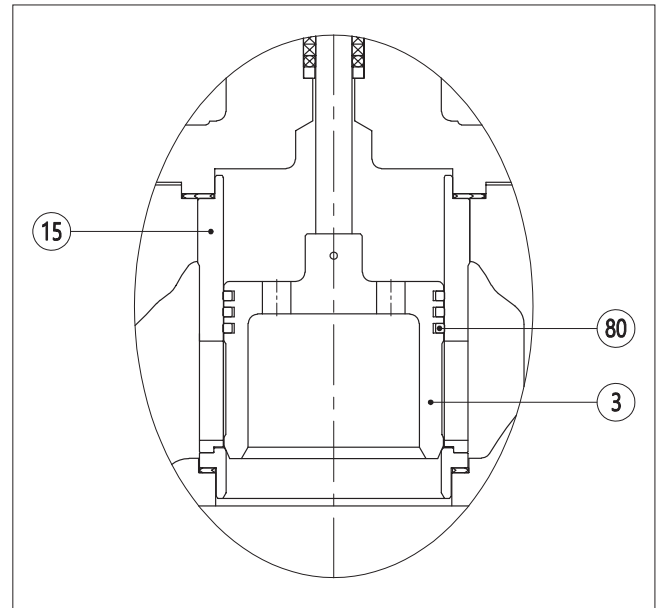

Fig. 10 High temp balanced trim

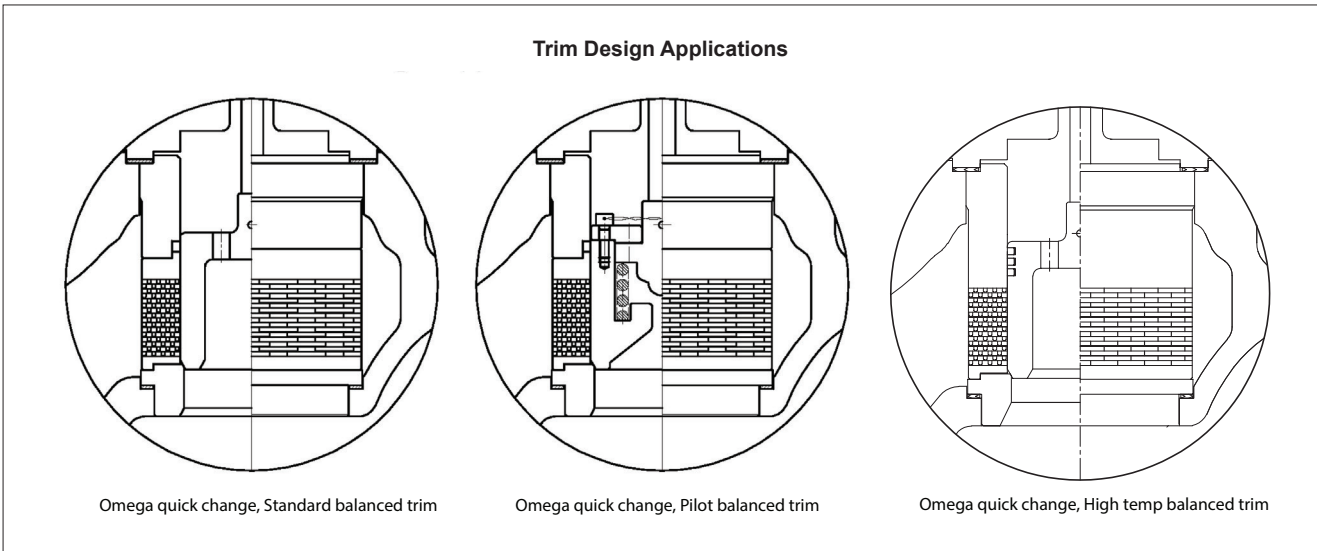

Fig. 11 Different trim designs.

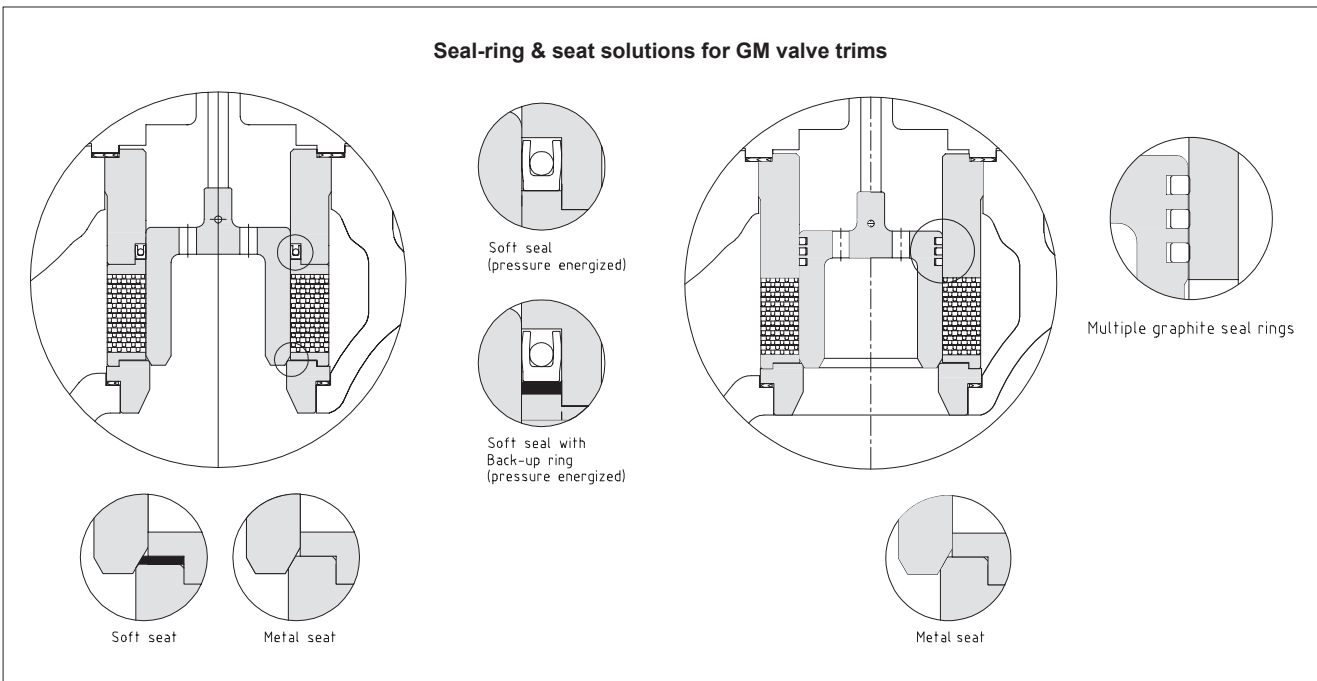

Fig. 12 Seal ring applications

5. TESTING THE VALVE

CAUTION:
Pressure testing should be carried out using equipment conforming to the correct pressure class!

We recommend that the valve body is pressure-tested after the valve has been assembled.

The pressure test should be carried out in accordance with an applicable standard for the pressure rating. The valve must be in the open position during the test.

6. REMOVAL & MOUNTING THE ACTUATOR

The actuator is attached to the valve according to the manual for actuator with body assembly and plug stem adjustment . Several types of Neles actuators can be used with suitable clamps. Refer to the model VD spring-diaphragm and VC double acting cylinder actuator manuals for further information on their installation, maintenance and operation.

CAUTION:

Make sure the valve is not pressurized when removing the actuator

CAUTION:

Beware of the plug movement!

Do not use air pressure higher than what specified on the identification plate.

NOTE:

Threaded area is required to apply lubricant suitable for process temperature to yoke nut(3**) and clamp(1**).

A. Actuator removal for Reverse <air to open, stem retract> actuator (Fig. 14)

- Lift up to the valve plug more than 20 % from the seat ring, using by specified air pressure.
- Loosen the stem lock nut (5**) and socket head screws (1a**) and hexagon nuts (1b**).
- Remove the clamp (1**).
- Shut off and disconnect air supply line.
- Support actuator with the suitable lifting device.
- Remove the yoke nut (3**).
- Remove the actuator from the valve body assembly.

B. Actuator removal for Direct <air to close, stem extend> actuator (Fig. 14)

- Shut off and disconnect the air supply lines and accessories.
- Loosen stem lock nut (5**) and socket head screws (1a**) and hexagon nuts (1b**).
- Remove the clamp (1**).
- Support actuator with the suitable lifting device.
- Remove the yoke nut (3**).
- Remove the actuator from the valve body assembly.

General & high temp balanced trim constructions

- With the handwheel or pneumatically, push the valve stem and plug to be slightly touched with seat ring to make sure if valve is fully closed.
- With the handwheel or pneumatically, stroke the actuator to the fully open.
- Measure the maximum distance between the valve stem and actuator top stem.
- Calculate the gap (measured value – rated travel = gap 1)
- Move down the top stem so that the distance between the valve stem and actuator top stem should be gap 1
- Fit the clamp to align with both stems thread
- Line up the stroke indicator with the clamp indicator arrow and check actuator for operation.
- Tighten the socket head screws after adjusted the rated stroke.

Pilot valve construction

- With the handwheel or pneumatically, push the valve stem and plug to be slightly touched with seat ring to make sure if valve is fully closed. And mark the valve stem end location by a line on the yoke or travel indicator.
- And move up the top stem. And mark the valve stem end location by a line on the yoke or travel indicator after valve stem is moved by a spring inside pilot plug.
- Measure the distance between two lines, which is gap 2.
- Stroke the actuator to the fully open.
- Measure the maximum distance between the valve stem and actuator top stem.
- Calculate the gap (measured value – rated travel – gap 2 = gap 3)
- Move down the top stem so that the distance between the valve stem and actuator top stem should be gap 2
- Fit the clamp to align with both stems thread
- Close the valve fully.
- Line up the stroke indicator with the clamp indicator arrow and check actuator for operation.
- Tighten the socket head screws after adjusted the rated stroke.

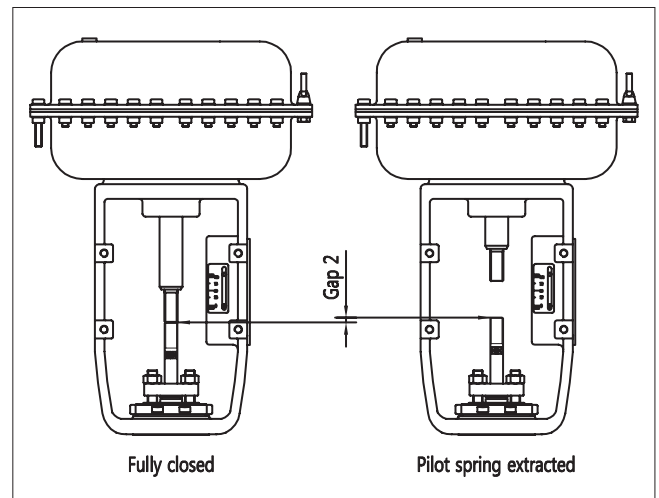
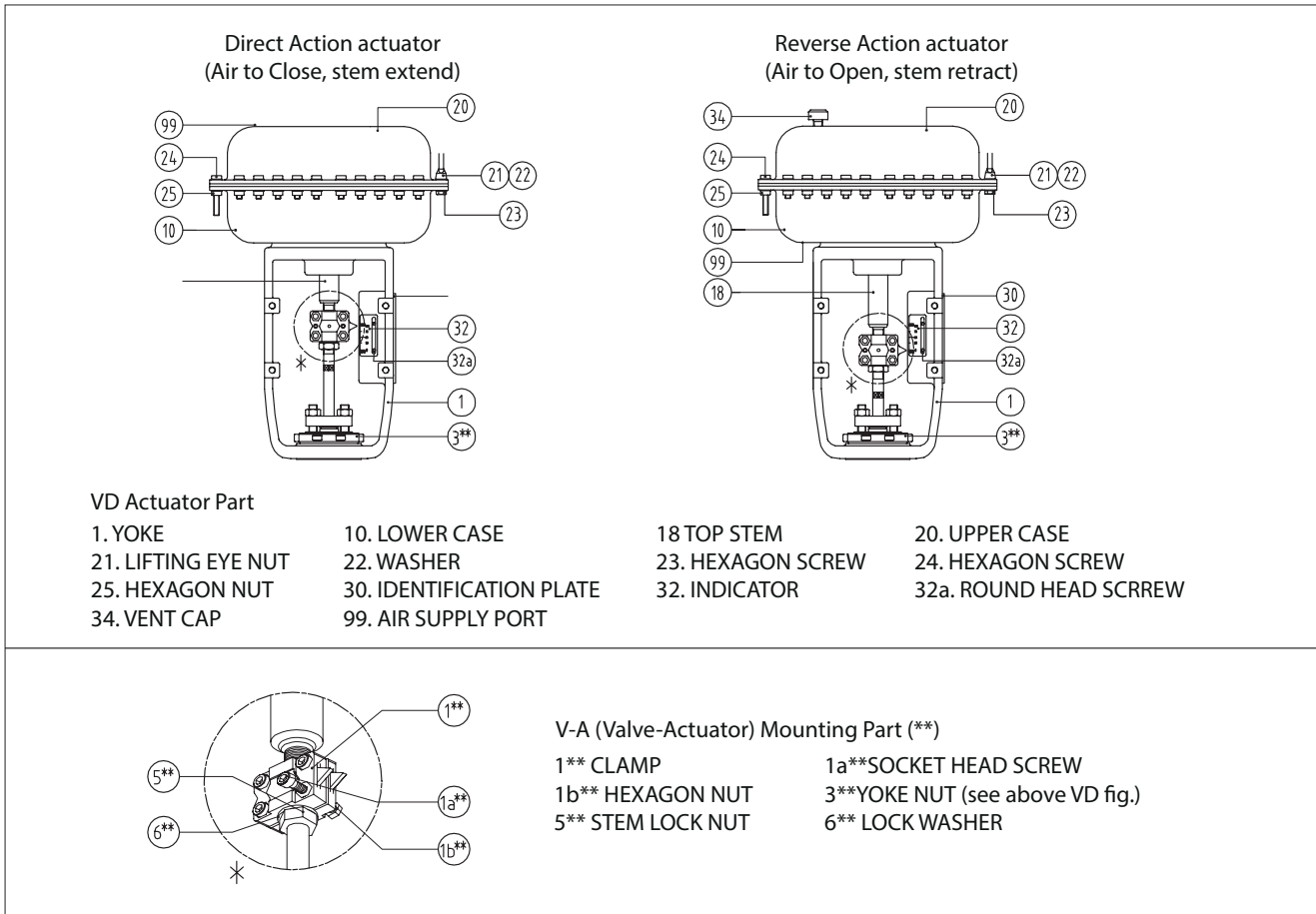

Fig. 13 Measurement of Gap 2

C. Actuator replacement (mounting)

- Mount the new or repaired actuator on top of the bonnet, using a suitable lifting device.
- Insert the yoke nut and tightly fasten the yoke by turning the yoke nut clockwise using tightening tools.
- Connect air line and accessories.
- Tighten stem socket head screws (1a**) and hexagon nuts (1b**) with stem lock nut (5**).



VD Actuator

D. Type 'VC' Springless Cylinder, Double Acting Actuator

- This actuator is springless cylinder, double acting actuator, can use the 3/8", 1/2" NPT port according to specified on the data sheet for all air lines.
- Refer to the model VC double acting cylinder actuator manuals for further information on their installation, maintenance and operation

CAUTION:
Avoid to turn the valve plug and stem when plug is on seat ring to prevent the seating line from being damaged.

7. TOOLS

- Removal of the actuator
- L- wrench set(mm)
 - hex socket wrench set
 - chisel and hammer (10 pound)
 - +,- drivers

8. ORDERING SPARE PARTS

NOTE:
Always use original spare parts to make sure that the valve functions as intended.

When ordering spare parts, always include the following information:

- type code, sales order number, serial number
- number of the parts list, part number, name of the part and quantity required

This information can be found from the identification plate or documents.

9. EXPLODED VIEW AND PARTS LIST

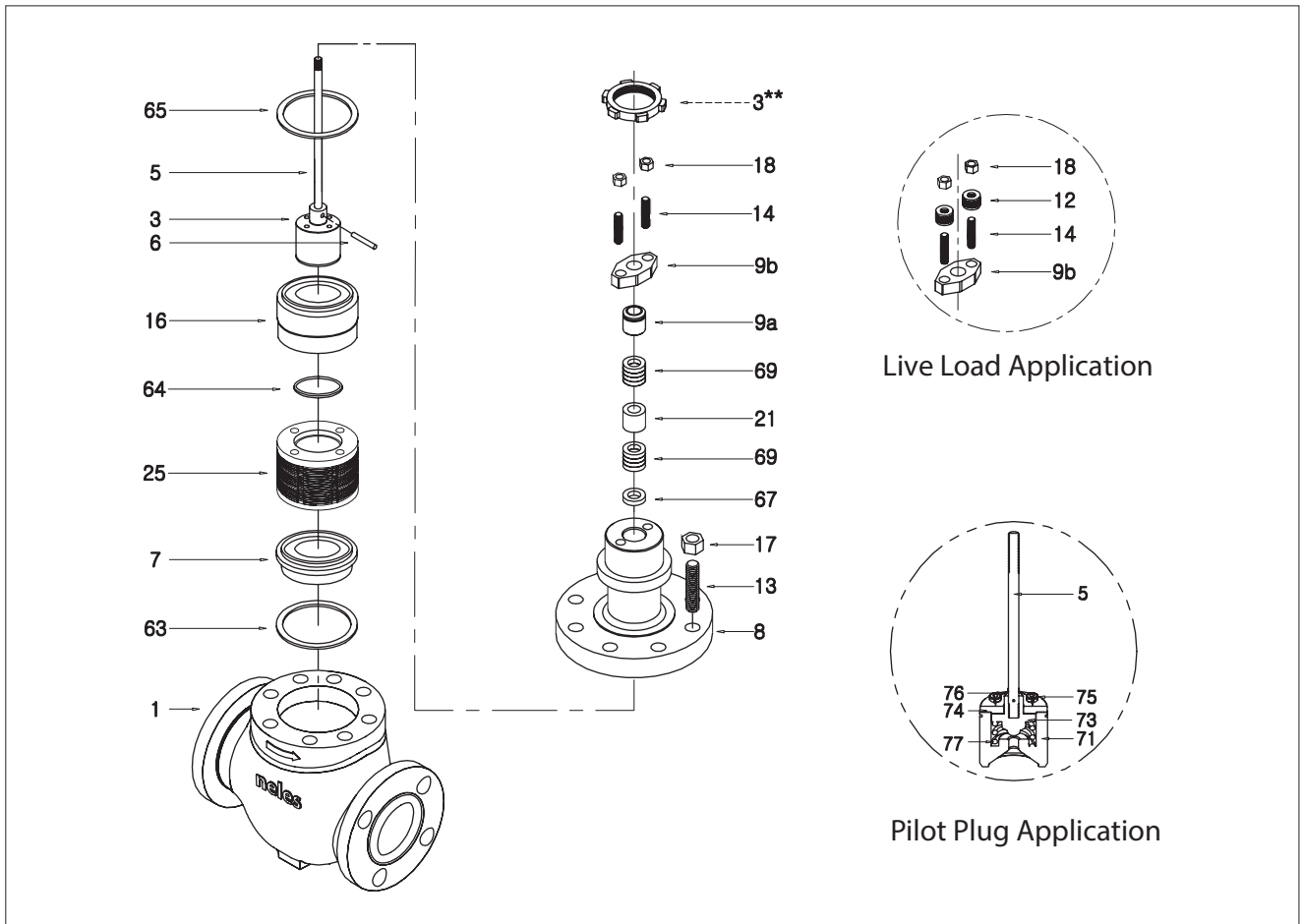

Item	Description	Recommended spare part
1	BODY	
2*	PLUG SET	
	3* PLUG	
	5* STEM	
	6* PLUG PIN	
3**	YOKE NUT	
7	SEAT RING	
8	BONNET	
9a	GLAND	
9b	GLAND FLANGE	
12	DISK SPRING ASS'Y	
13	STUD	
14	STUD	
16	CAGE GUIDE	
17	HEXAGON NUT	
18	HEXAGON NUT	
19	IDENTIFICATION PLATE	
19A	RIVET	
21	LANTERN RING	
25	DISK STACK	
63	SEAT GASKET	X
64	SEAL RING	X
65	BODY GASKET	X
67	PACKING SPACER	
69	PACKING RING	X
71	PILOT MAIN PLUG	
73	PILOT PLUG	
74	PILOT COVER	
75	PILOT BOLT	
76	PILOT WIRE	
77	PILOT SPRING (Located inside the pilot main plug, see Fig. 8 at page 7)	

*) Delivered as a set
 **) V-A Mounting Parts

10. DIMENSIONS AND WEIGHTS

10.1 Valve GM

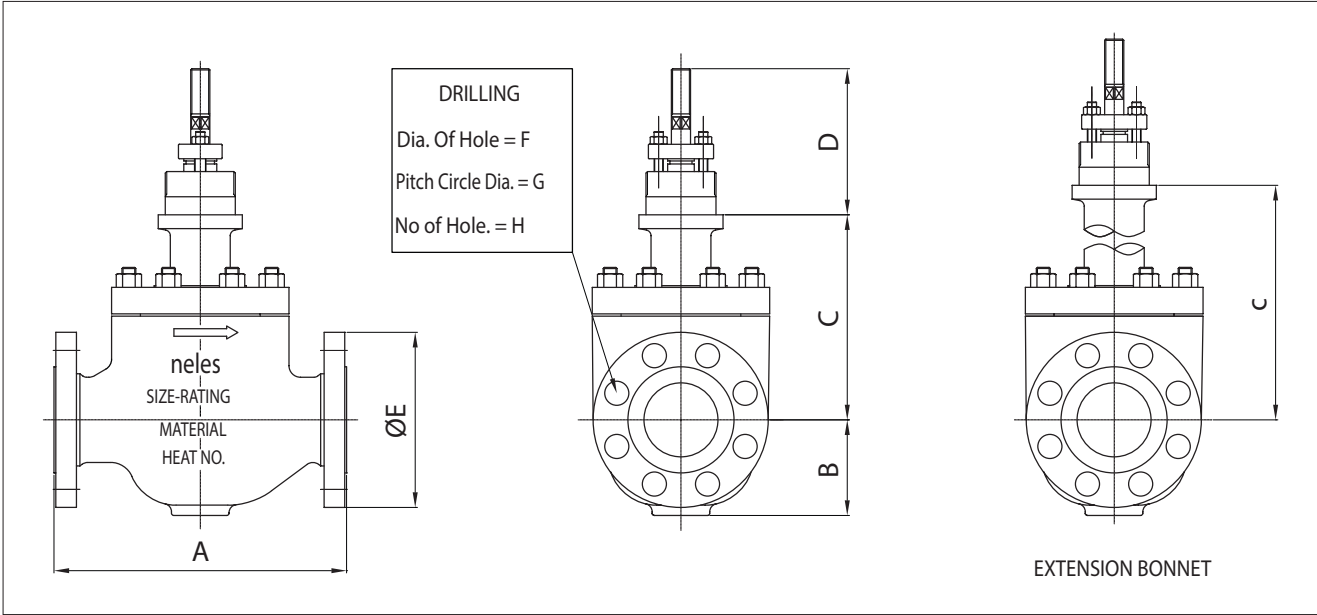

150 #/ 300 #/ 600

Dimension (mm)	A			B			C		D	E			F			G			H			Weight (kg)		
	150#	300#	600#	150#	300#	600#	STD	EXT	COMMON	150#	300#	600#	150#	300#	600#	150#	300#	600#	150#	300#	600#	150#	300#	600#
25	184	197	210	55	63	63	142	250	110	110	125	125	15.9	19.1	19.1	79.4	88.9	88.9	4	4	4	14	15	23
40	222	235	251	65	78	78	161	269	110	125	155	155	15.9	22.2	22.2	98.4	114.3	114.3	4	4	4	22	23	27
50	254	267	286	83	83	83	178	333	110	150	165	165	19.1	19.1	19.1	120.7	127	127	4	8	8	30	32	40
80	298	318	337	109	109	120	222	395	115	190	210	210	19.1	22.2	22.2	152.4	168.3	168.3	4	8	8	65	67	72
100	352	368	394	135	135	135	248	402	140	230	255	275	19.1	22.2	25.4	190.5	200	215.9	8	8	8	100	103	112
150	451	473	508	170	170	178	340	467	150	280	355	355	22.2	22.2	28.6	241.3	269.9	292.1	8	12	12	185	195	240
200	543	568	610	230	230	230	451	557	150	345	420	420	22.2	25.4	31.8	298.5	330.2	349.2	8	12	12	363	385	443
250	673	708	752	275	275	275	488	670	150	405	510	510	25.4	28.6	34.9	362	387.4	431.8	12	16	16	552	595	681
300	737	775	819	350	350	350	543	716	140	485	560	560	25.4	31.8	34.9	431.8	450.8	489	12	16	20	905	955	1020
350	889	927	972	385	385	385	616	846	210	535	605	605	28.6	31.8	38.1	476.3	514.4	527	12	20	20	1170	1230	1311
400	1016	1057	1108	440	440	440	692	909	220	595	685	685	28.6	34.9	41.3	539.8	571.5	603.2	16	20	20	1380	1460	1587

Dimension (mm)	A			B			C		D	E			F			G			H			Weight (lbs)		
	150#	300#	600#	150#	300#	600#	STD	EXT	COMMON	150#	300#	600#	150#	300#	600#	150#	300#	600#	150#	300#	600#	150#	300#	600#
1"	7.2	7.8	8.3	2.2	2.5	2.5	5.6	9.8	4.3	4.3	4.9	4.9	0.6	0.8	0.8	3.1	3.5	3.5	4	4	4	31	33	51
1-1/2"	8.7	9.3	9.9	2.6	3.1	3.1	6.3	10.59	4.3	4.9	6.1	6.1	0.6	0.9	0.9	3.9	4.5	4.5	4	4	4	49	51	60
2"	10	10.5	11.3	3.3	3.3	3.3	7	13.11	4.3	5.9	6.5	6.5	0.8	0.8	0.8	4.8	5	5	4	8	8	66	71	88
3"	11.7	12.5	13.3	4.3	4.3	4.7	8.7	15.55	4.5	7.5	8.3	8.3	0.8	0.9	0.9	6	6.6	6.6	4	8	8	143	148	159
4"	13.9	14.5	15.5	5.3	5.3	5.3	9.8	15.82	5.5	9.1	10	10.8	0.8	0.9	1	7.5	7.9	8.5	8	8	8	221	227	247
6"	17.8	18.6	20	6.7	6.7	7	13.4	18.38	5.9	11	12.6	14	0.9	0.9	1.1	9.5	10.6	11.5	8	12	12	408	430	529
8"	21.4	22.4	24	9.1	9.1	9.1	17.8	21.92	5.9	13.6	15	16.5	0.9	1	1.3	11.8	13	13.7	8	12	12	800	849	977
10"	26.5	27.9	29.6	10.8	10.8	10.8	19.2	26.37	5.9	15.9	17.5	20.1	1	1.1	1.4	14.3	15.3	17	12	16	16	1217	1312	1501
12"	29	30.5	32.2	13.8	13.8	13.8	21.4	28.18	5.9	19.1	20.5	22	1	1.3	1.4	17	17.7	19.3	12	16	20	1995	2105	2249
14"	35	36.5	38.3	15.2	15.2	15.2	24.3	33.30	8.3	21.1	23	23.8	1.1	1.3	1.5	18.8	20.3	20.7	12	20	20	2579	2712	2890
16"	40	41.6	43.6	17.3	17.3	17.3	27.2	35.78	8.7	23.4	25.6	27	1.1	1.4	1.6	21.3	22.5	23.7	16	20	20	3042	3219	3499

900 #/ 1500 #

Dimension (mm)	A		B		C		D	E		F		G		H		Weight (kg)	
	900#	1500#	900#	1500#	STD	EXT	COMMON	900#	1500#	900#	1500#	900#	1500#	900#	1500#	900#	1500#
25	292	292	82	82	236	330	110	150	180	25.4	25.4	101.6	101.6	4	4	60	60
40	333	333	90	90	248	380	110	180	180	28.6	28.6	123.8	123.8	4	4	63	63
50	375	375	113	113	315	380	110	215	215	25.4	25.4	165.1	165.1	8	8	67	67
80	441	460	142	142	335	430	115	240	265	25.4	31.8	190.5	203.2	8	8	150	163
100	511	530	182	182	375	475	140	290	310	31.8	34.9	235	241.3	8	8	244	255
150	714	768	210	240	420	500	150	380	395	31.8	39	317.5	317.5	12	12	530	540
200	914	972	290	290	550	600	150	470	485	38.1	45	393.7	393.7	12	12	698	821
250	991	1067	310	350	600	700	150	545	585	38.1	51	469.9	482.6	16	12	955	1137
300	1130	1219	385	385	680	800	140	610	675	38.1	54	533.4	571.5	20	16	1180	1240
350	1257	1257	385	385	770	920	210	640	750	41.3	61	558.8	635	20	16	1387	1477
400	1422	1422	450	450	850	1050	220	705	825	44.5	67	616	704.8	20	16	1601	1721

Dimension (inch)	A		B		C		D	E		F		G		H		Weight (lbs)	
	900#	1500#	900#	1500#	STD	EXT	COMMON	900#	1500#	900#	1500#	900#	1500#	900#	1500#	900#	1500#
1"	11.5	11.5	3.2	3.2	9	13	4	5.9	7.1	1	1	4	4	4	4	132	132
1-1/2"	13.1	13.1	3.5	3.5	10	15	4	7.1	7.1	1.1	1.1	4.9	4.9	4	4	139	139
2"	14.8	14.8	4.4	4.4	12	15	4	8.5	8.5	1	1	6.5	6.5	8	8	148	148
3"	17.4	18.1	5.6	5.6	13	17	5	9.4	10.4	1	1.3	7.5	8	8	8	331	359
4"	20.1	20.9	7.2	7.2	15	19	6	11.4	12.2	1.3	1.4	9.3	9.5	8	8	538	562
6"	28.1	30.2	8.3	9.4	17	20	6	15	15.6	1.3	1.5	12.5	12.5	12	12	1168	1191
8"	36	38.3	11.4	11.4	22	24	6	18.5	19.1	1.5	1.8	15.5	15.5	12	12	1539	1810
10"	39	42	12.2	13.8	24	28	6	21.5	23	1.5	2	18.5	19	16	12	2105	2507
12"	44.5	48	15.2	15.2	27	31	6	24	26.6	1.5	2.1	21	22.5	20	16	2602	2734
14"	49.5	49.5	15.2	15.2	30	36	8	25.2	29.5	1.6	2.4	22	25	20	16	3058	3256
16"	56	56	17.7	17.7	33	41	8	27.8	32.5	1.8	2.6	24.3	27.7	20	16	3530	3794

* Bigger sizes and ASME class 2500 & 4500 ratings are available, please contact Valmet.

10.2 Actuator VDD/VDR

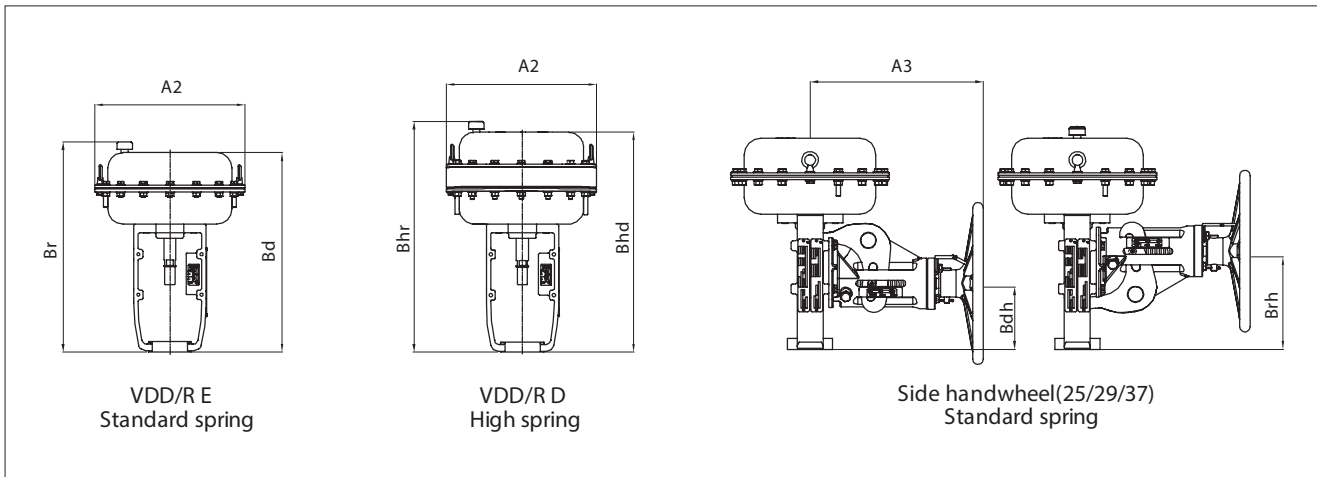

Dimension (mm)	Size (mm)	Without handwheel				With handwheel				
		A2	Bd / Bhd	Br / Bhr	Weight (kg)	A2	A3	Bdh	Brh	Weight (kg)
VD_25 E		255	348	373	12	255	312	110	170	23
VD_25 D		255	373	395	17	255	312	110	170	28
VD_29 E		295	391	416	18	295	312	122	182	29
VD_29 D		295	431	453	26	295	312	122	182	32
VD_37 E		375	464	489	28	375	352	131	211	43
VD_37 D		375	514	535	46					

Dimension (inch)	Size (inch)	Without handwheel				With handwheel				
		A2	Bd / Bhd	Br / Bhr	Weight (lbs)	A2	A3	Bdh	Brh	Weight (lbs)
VD_25 E		10	14	15	26	10	12	4	7	51
VD_25 D		10	15	16	37	10	12	4	7	62
VD_29 E		12	15	16	40	12	12	5	7	64
VD_29 D		12	17	18	57	12	12	5	7	82
VD_37 E		15	18	19	62	15	14	5	8	95
VD_37 D		15	20	21	101					

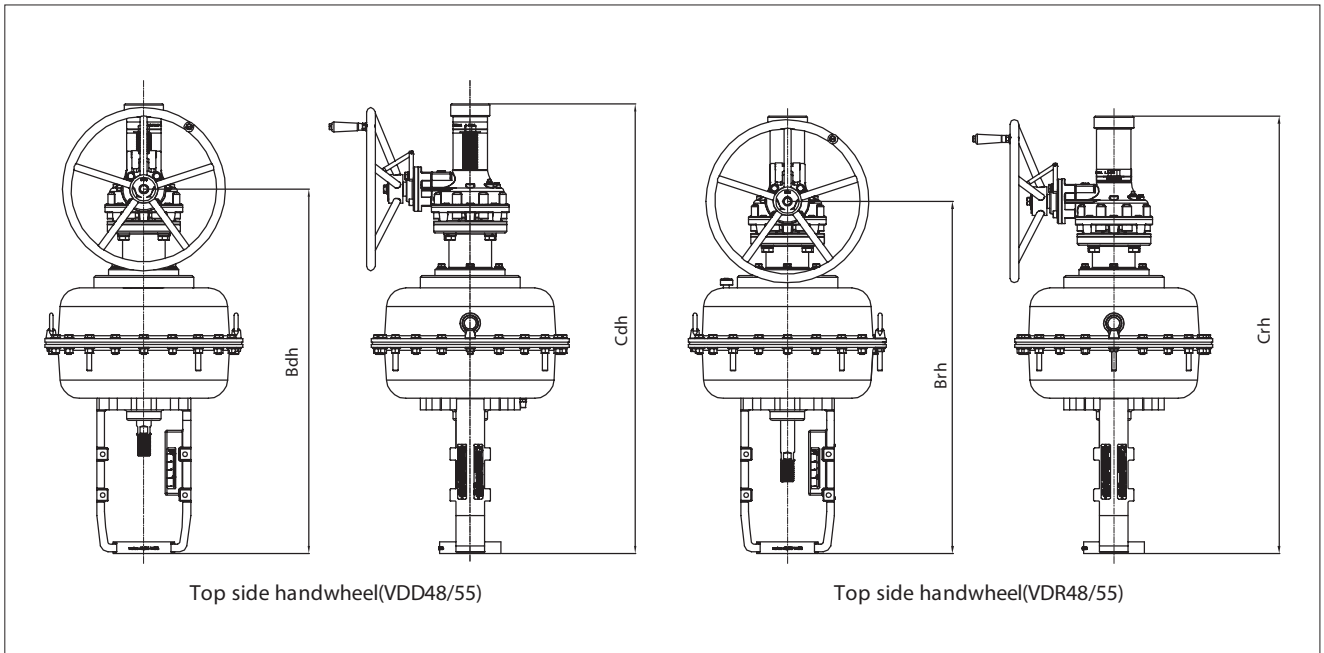

Dimension (mm)	Size (mm)	Without handwheel				With handwheel				
		A2	Bd / Bhd	Br / Bhr	Weight (kg)	Bdh	Brh	Cdh	Crh	Weight (kg)
VD_48 E		486	652	677	86	896	865	1102	1072	112
VD_48 D		486	702	724	118	946	915	1152	1122	144
VD_55 E		566	695	720	112	940	910	1145	1115	145
VD_55 D		566	745	767	152					

Dimension (inch)	Size (inch)	Without handwheel				With handwheel				
		A2	Bd / Bhd	Br / Bhr	Weight (lbs)	Bdh	Brh	Cdh	Crh	Weight (lbs)
VD_48 E		19	26	27	190	35	34	43	42	247
VD_48 D		19	28	29	260	37	36	45	44	317
VD_55 E		22	27	28	247	37	36	45	44	320
VD_55 D		22	29	30	335					

NOTE

1. "E" refers to Spring range 0.8~2.6
2. "D" refers to Spring range 1.5~3.4
3. "Br / Bhr" refers to reverse acting actuator, VDR E / D
4. "Bd / Bhd" refers to direct acting actuator, VDD E / D
5. "Cdh / Crh" Top side handwheel actuator, VD_48/55

10.3 Actuator VBD/R

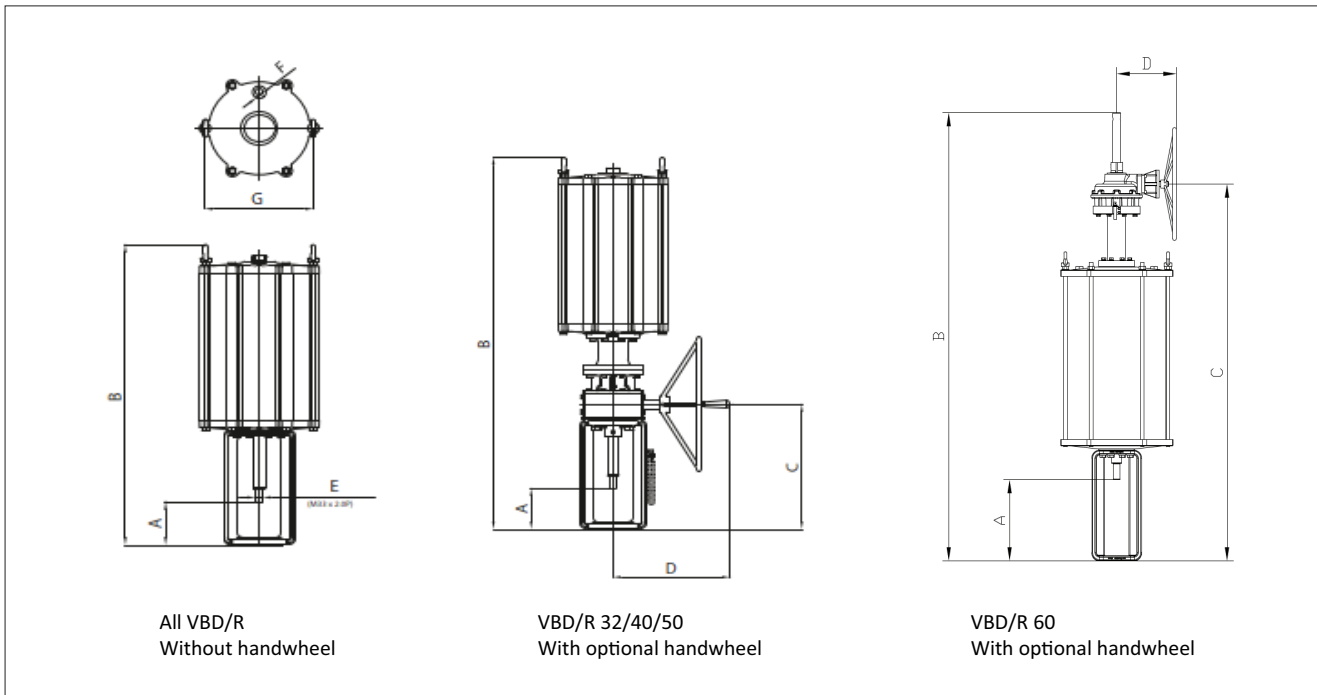

Dimension (mm) Size	Stroke Range	Without handwheel					With handwheel				
		A	B	F	G	Weight (kg)	A	B	C	D	Weight (kg)
VBD/R32	50,60,70,80,120	153	1064	3/4" NPT	392	145	155	1388	466	401	199
VBD/R40	60,70,80,120,140,160,180	185	1450	3/4" NPT	497	290	178	1800	619	427	268
VBD/R50	60,70,80,120,140,160,180	185	1535	1" NPT	610	485	178	1885	619	427	563

Dimension (inch) Size	Stroke Range	Without handwheel					With handwheel				
		A	B	F	G	Weight (lbs)	A	B	C	D	Weight (lbs)
VBD/R32	50,60,70,80,120	6	41.9	3/4" NPT	15.4	320	6.1	54.6	18.3	15.8	439
VBD/R40	60,70,80,120,140,160,180	7.2	57.1	3/4" NPT	19.6	639	7	70.9	24.4	16.8	591
VBD/R50	60,70,80,120,140,160,180	7.2	60.4	1" NPT	24	1069	7	74.2	24.4	16.8	1241

10.4 Actuator VBC

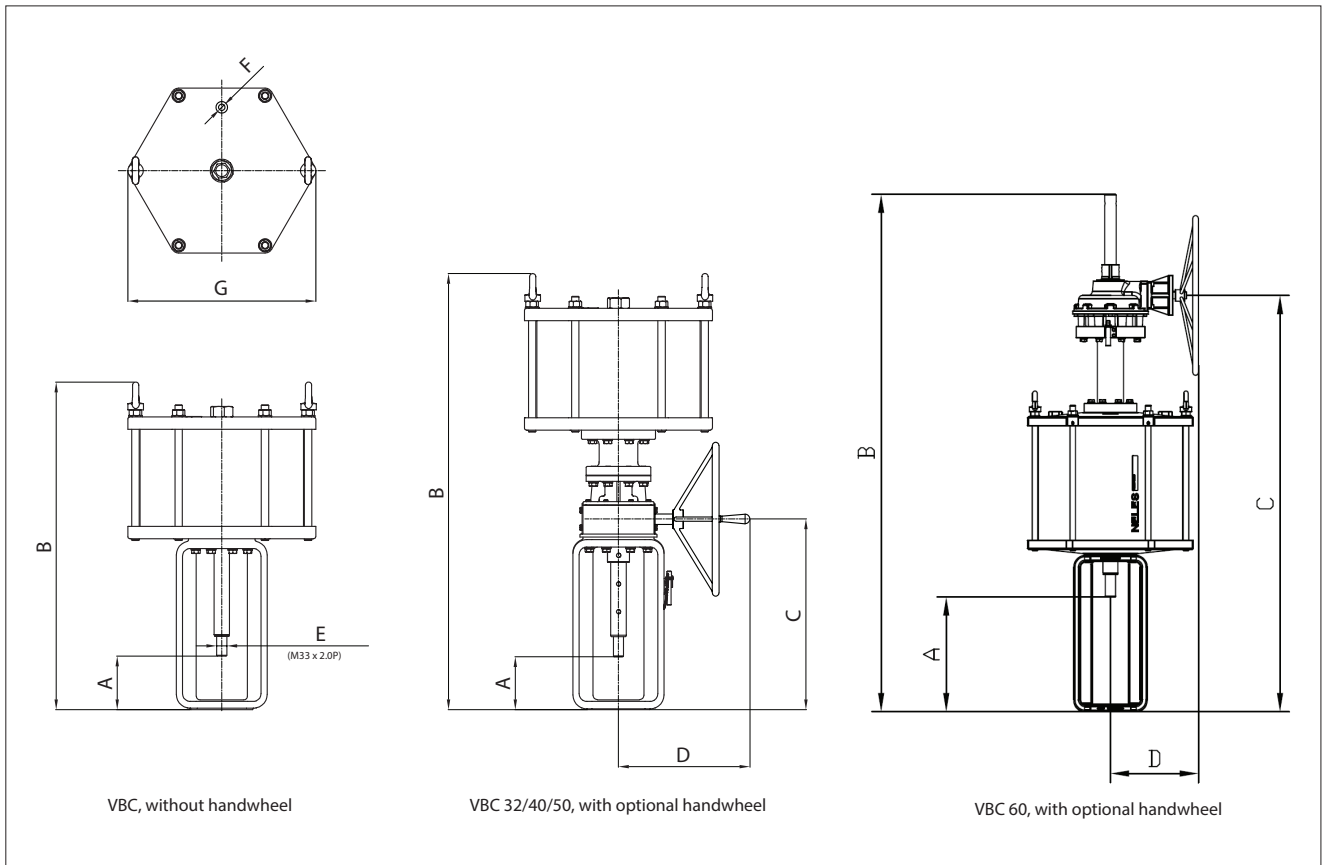

Dimension (mm) / Size	Stroke Range	Without handwheel					With handwheel				
		A	B	F	G	Weight (kg)	A	B	C	D	Weight (kg)
VBC32	50,60,70,80,120	153	769	3/4" NPT	392	96	158	1093	471	417	147
VBC40	60,70,80,120,140,160,180	185	1054	3/4" NPT	499	190	185	1403	619	427	263
VBC50	60,70,80,120,140,160,180	184	1066	1" NPT	610	297	179	1415	619	427	371

Dimension (mm) / Size	Stroke Range	Without handwheel					With handwheel				
		A	B	F	G	Weight (lbs)	A	B	C	D	Weight (lbs)
VBC32	50,60,70,80,120	6	30.3	3/4" NPT	15.4	212	6.2	43	18.5	16.4	324
VBC40	60,70,80,120,140,160,180	7.3	41.5	3/4" NPT	19.6	419	7.3	55.2	24.4	16.8	580
VBC50	60,70,80,120,140,160,180	7.2	42	1" NPT	24	655	7	55.7	24.4	16.8	818

10.5 Actuator VBC with volume chamber

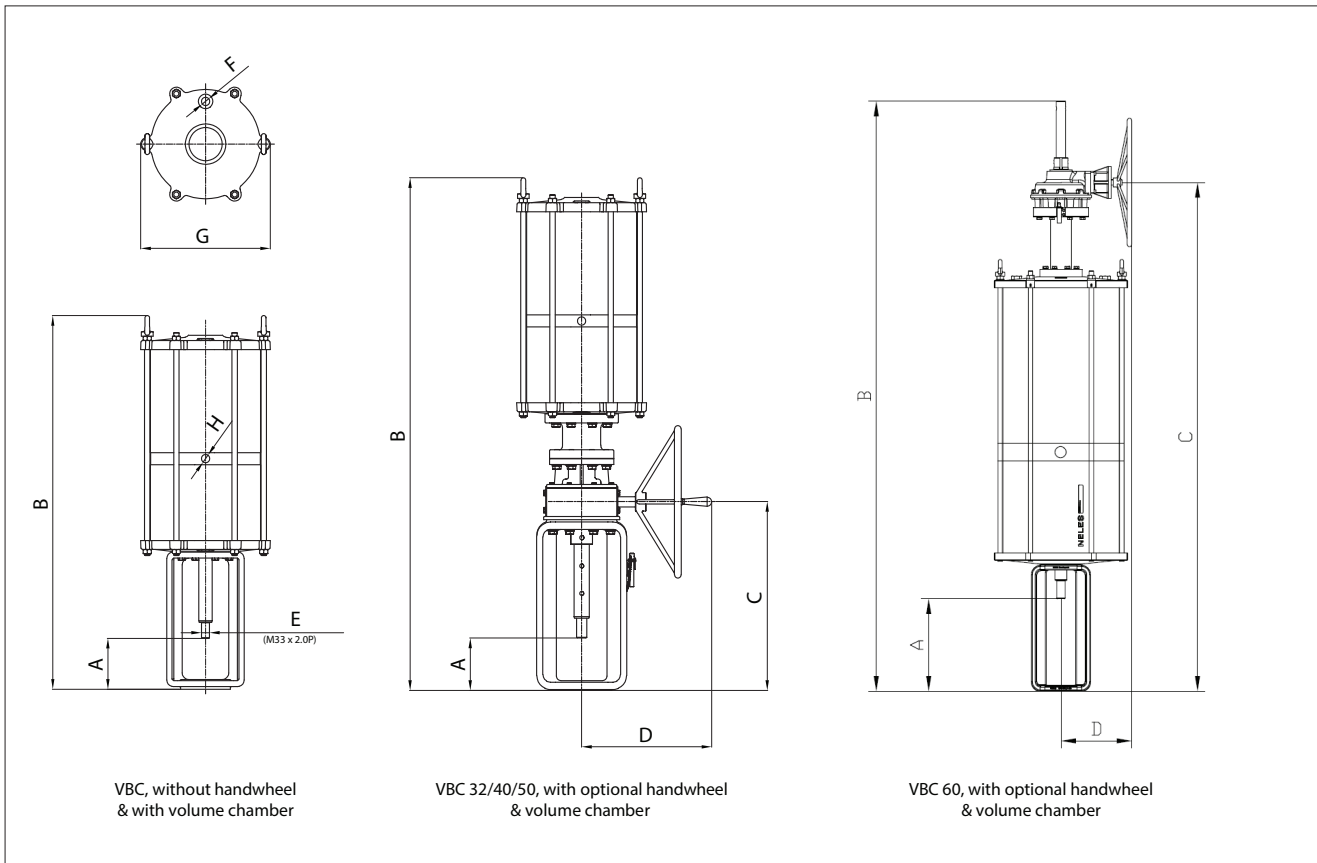

Dimension (mm) / Size	Stroke Range	Without handwheel						With handwheel				
		A	B	F	G	H	Weight (kg)	A	B	C	D	Weight (kg)
VBC32_V	50,60,70,80,120	153	1116	3/4" NPT	390	3/4" NPT	129	158	1440	471	417	180
VBC40_V	60,70,80,120,140,160,180	185	1550	3/4" NPT	499	3/4" NPT	255	185	1899	619	427	329
VBC50_V	60,70,80,120,140,160,180	184	1570	1" NPT	610	1" NPT	415	179	1919	619	427	490

Dimension (mm) / Size	Stroke Range	Without handwheel						With handwheel				
		A	B	F	G	H	Weight (lbs)	A	B	C	D	Weight (lbs)
VBC32_V	50,60,70,80,120	6	43.9	3/4" NPT	15.4	3/4" NPT	284	6.2	56.7	18.5	16.4	397
VBC40_V	60,70,80,120,140,160,180	7.3	61	3/4" NPT	19.7	3/4" NPT	562	7.3	74.8	24.4	16.8	725
VBC50_V	60,70,80,120,140,160,180	7.2	61.8	1" NPT	24	1" NPT	915	7	75.6	24.4	16.8	1080

10.6 Actuator VCC without handwheel

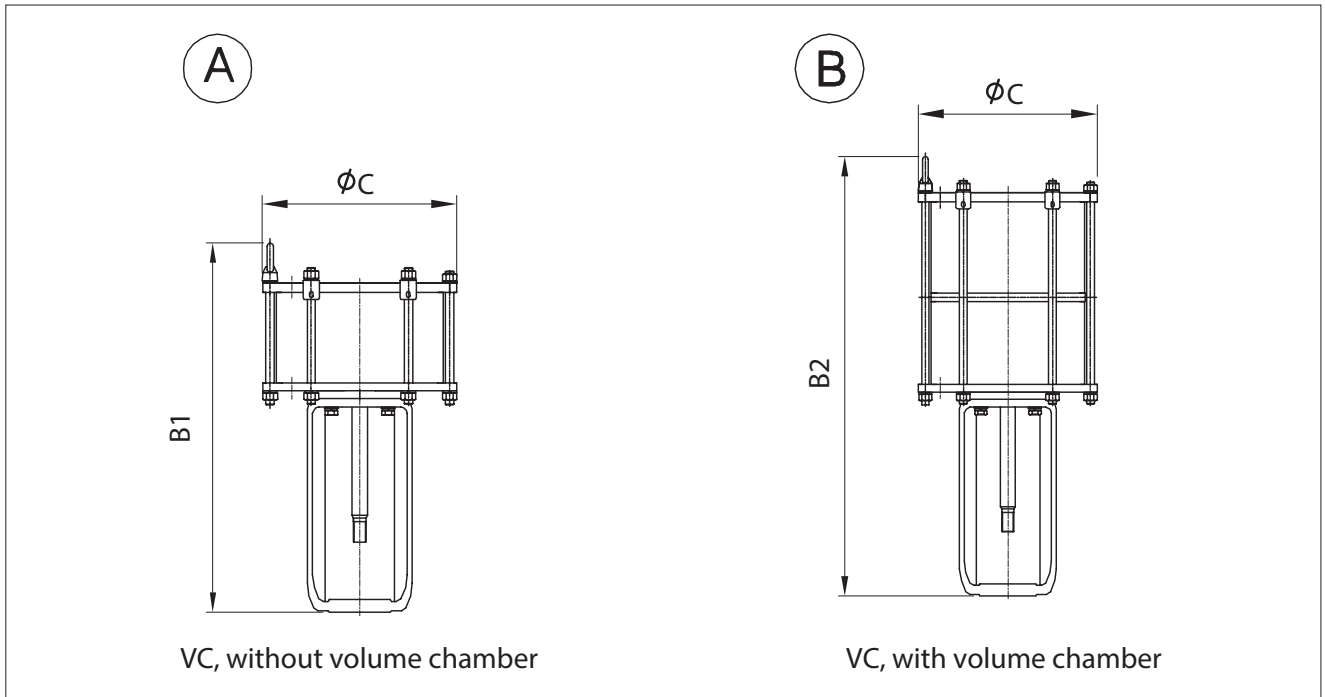

VC actuator without handwheel

Stroke (mm)	# 30				# 40			# 50		
	C	370		C	460		C	560		
	B1	Weight (kg)		B1	Weight (kg)		B1	Weight (kg)		
	B2	A	B	B2	A	B	B2	A	B	
40	640	92	115	810	120	148	810	186	234	
	760			935			935			
50	650	94	118	820	123	152	820	189	237	
	790			965			965			
60	660	97	121	830	126	155	830	192	242	
	820			995			995			
70	670	100	124	840	128	159	840	195	246	
	850			1025			1025			
80	680	103	127	850	131	162	850	198	251	
	880			1055			1055			
90	690	106	130	860	134	166	860	201	256	
	910			1085			1085			
100	700	108	133	870	137	173	870	203	261	
	940			1115			1115			
120	720	114	139	890	142	177	890	209	270	
	1000			1175			1175			
140				910	148	184	910	215	279	
				1235			1235			
180				950	159	198	950	227	298	
				1355			1355			

Stroke (mm)	# 60			# 70			# 80		
	C	660		C	710		C	820	
	B1	Weight (kg)		B1	Weight (kg)		B1	Weight (kg)	
	B2	A	B	B2	A	B	B2	A	B
100	954	255	344	955	322	438	954	378	519
	1199			1203			1207		
120	974	262	355	975	330	450	974	386	531
	1259			1263			1267		
140	994	269	365	995	338	461	994	394	543
	1319			1323			1327		
180	1034	283	386	1035	354	484	1034	410	567
	1439			1443			1447		
240	1094	303	417	1095	377	518	1094	435	604
	1619			1623			1627		
280							1134	451	628
							1747		

VC actuator without handwheel

Stroke (mm)	# 30				# 40			# 50		
	C	15		C	18		C	22		
	B1	Weight (lbs)		B1	Weight (lbs)		B1	Weight (lbs)		
	B2	A	B	B2	A	B	B2	A	B	
40	25	203	254	32	265	326	32	410	516	
	30			37			37			
50	26	207	260	32	271	335	32	417	522	
	31			38			38			
60	26	214	267	33	278	342	33	423	534	
	32			39			39			
70	26	220	273	33	282	351	33	430	542	
	33			40			40			
80	27	227	280	33	289	357	33	437	553	
	35			42			42			
90	27	234	287	34	295	366	34	443	564	
	36			43			43			
100	28	238	293	34	302	381	34	448	575	
	37			44			44			
120	28	251	306	35	313	390	35	461	595	
	39			46			46			
140				36	326	406	36	474	615	
				49			49			
180				37	351	437	37	500	657	
				53			53			

Stroke (mm)	# 60			# 70			# 58		
	C	26		C	28		C	32	
	B1	Weight (lbs)		B1	Weight (lbs)		B1	Weight (lbs)	
	B2	A	B	B2	A	B	B2	A	B
100	38	562	758	38	710	966	37	833	1144
	47			47			48		
120	38	578	783	38	728	992	38	851	1171
	50			50			50		
140	39	593	805	39	745	1016	39	869	1197
	52			52			52		
180	41	624	851	41	780	1067	41	904	1250
	57			57			57		
240	43	668	919	43	831	1142	43	959	1332
	64			64			64		
280							45	994	1385
							69		

10.7 Actuator VCC with handwheel

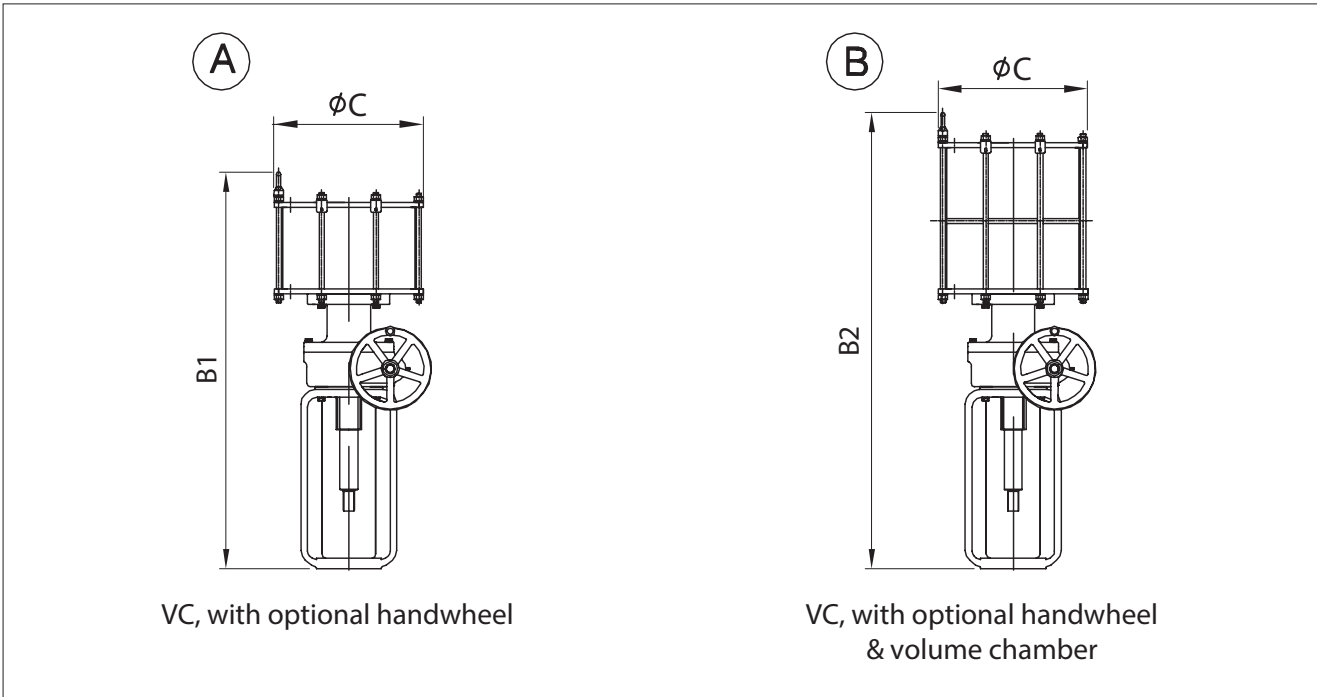

VC actuator with handwheel

Stroke (mm)	#30				#40				#50			
	C		370		C		460		C		560	
	B1	B2	Weight (kg)		B1	B2	Weight (kg)		B1	B2	Weight (kg)	
		A	B			A	B			A	B	
40	930		134	157	1095		180	208	1095		246	294
	1055				1220				1220			
50	940		137	160	1105		183	212	1105		249	299
	1085				1250				1250			
60	950		139	163	1115		186	215	1115		252	303
	1115				1280				1280			
70	960		142	167	1125		188	219	1125		255	308
	1145				1310				1310			
80	970		144	170	1135		191	222	1135		258	313
	1175				1340				1340			
90	980		147	173	1145		194	226	1145		261	318
	1205				1370				1370			
100	990		150	176	1155		197	230	1155		263	322
	1235				1400				1400			
120	1010		155	183	1175		202	237	1175		269	332
	1295				1460				1460			
140					1195		208	244	1195		275	341
					1520				1520			
180					1235		219	258	1235		287	360
					1640				1640			

Stroke (mm)	#60				#70				#80			
	C		660		C		710		C		820	
	B1	B2	Weight (kg)		B1	B2	Weight (kg)		B1	B2	Weight (kg)	
		A	B			A	B			A	B	
100	1239		315	404	1240		368	502	1289		438	579
	1484				1488				1542			
120	1259		322	415	1260		376	514	1309		446	591
	1544				1548				1602			
140	1279		329	425	1280		384	525	1329		454	603
	1604				1608				1662			
180	1319		343	446	1320		400	548	1369		470	627
	1724				1728				1782			
240	1379		363	477	1380		423	582	1429		495	664
	1904				1908				1962			
280									1469		511	688
									2082			

VC actuator with handwheel

Stroke (mm)	#30				#40				#50			
	C		15		C		18		C		22	
	B1	B2	Weight (lbs)		B1	B2	Weight (lbs)		B1	B2	Weight (lbs)	
		A	B			A	B			A	B	
40	37		295	346	43		397	459	43		542	648
	42				48				48			
50	37		302	353	44		403	467	44		549	659
	43				49				49			
60	37		306	359	44		410	474	44		556	668
	44				50				50			
70	38		313	368	44		414	483	44		562	679
	45				52				52			
80	38		317	375	45		421	489	45		569	690
	46				53				53			
90	39		324	381	45		428	498	45		575	701
	47				54				54			
100	39		331	388	45		434	507	45		580	710
	49				55				55			
120	40		342	403	46		445	522	46		593	732
	51				57				57			
140					47		459	538	47		606	752
					60				60			
180					49		483	569	49		633	794
					65				65			

Stroke (mm)	#60				#70				#80			
	C		26		C		28		C		32	
	B1	B2	Weight (lbs)		B1	B2	Weight (lbs)		B1	B2	Weight (lbs)	
		A	B			A	B			A	B	
100	49		694	891	49		811	1107	51		966	1276
	58				58				61			
120	50		710	915	50		829	1133	52		983	1303
	61				61				63			
140	50		725	937	50		847	1157	52		1001	1329
	63				63				65			
180	52		756	983	52		882	1208	54		1036	1382
	68				68				70			
240	54		800	1052	54		933	1283	56		1091	1464
	75				75				77			
280									58		1127	1517
									82			

11. TYPE CODE

Globe single seated, OMEGA trim type, Series GM																					
1.	2.	3.	4.	5.	6.	7.	8.	9.	10.	11.	12.	13.	14.	15.	16.	17.	18.	19.	20.	21.	22.
GM	02	C	E	A	J2	B	P2	X	BC	S1	P2	X	S	G	G	S	G	X	A	E	FG

VALVE CONSTRUCTIONS

1.	VALVE SERIES
GM	Globe Omega trim, Multi-stage type

2.	BODY SIZE		
01	1" / DN 25	1H	1-1/2" / DN 40
02	2" / DN 50	03	3" / DN 80
04	4" / DN 100	06	6" / DN 150
08	8" / DN 200	10	10" / DN 250
12	12" / DN 300	14	14" / DN 350
16	16" / DN 400	18	18" / DN 450
20	20" / DN 500	24	24" / DN 600
YY	Special		

3.	PRESSURE RATING		
C	ASME Class 150	D	ASME Class 300
F	ASME Class 600	G	ASME Class 900
H	ASME Class 1500	I	ASME Class 2500
J	EN PN 10	K	EN PN 16
L	EN PN 25	M	EN PN 40
N	EN PN 63	P	EN PN 100
B	EN PN 160	E	EN PN 250
Y	EN PN 320	R	JIS 10K
T	JIS 20K		

4.	END CONNECTION
W	Flanged RF, ASME B16.5
C	Flanged RF, EN 1092-1
V	Socket welding, ASME B16.11
Q	Butt welding, ASME B16.25
Z	Ring joint flange, ASME B16.5
Y	Special

5.	BONNET CONSTRUCTION	
	Bonnet Type	Actuator Connection
A	General	Applicable for VD_25/29/37
B	General	Applicable for VD_48/55
C	General	Applicable for VC_30, VB_32
D	General	Applicable for VC/VB_40/50/60/70
E	Extension	Applicable for VD_25/29/37
F	Extension	Applicable for VD_48/55
G	Extension	Applicable for VC_30, VB_32
H	Extension	Applicable for VC/VB_40/50/60/70
P	Cryogenic	Applicable for VD_25/29/37
Q	Cryogenic	Applicable for VD_48/55
R	Cryogenic	Applicable for VC_30, VB_32
S	Cryogenic	Applicable for VC/VB_40/50/60/70
Y	Special	Special

6.	BODY MATERIAL
J2	A216 gr WCB
S6	A351 g,r CF8M
J4	A217 gr. WC6
CG	A217 gr. WC9
S1	A351 gr. CF3M
YY	Special

- Bonnet material is equivalent to Body material.

7.	MODEL CODE
B	Model B

TRIM CONSTRUCTIONS

8.	PLUG MATERIAL	
	Material	Description
P2	CA40	General for carbon steel valve
T6	CF8M + HCr	General for stainless steel valve
YY	Special	Special

9.	PLUG APPLICATION
X	Not Applicable
A	Cobalt based alloy
Y	Special

10.	STEM MATERIAL	
	Material	Description
BC	630 SS + HCr	General for carbon steel valve
TC	316 SS + HCr	General for stainless steel valve
VX	XM-19	

11.	SEAT TYPE
S1	Single metal seat
YY	Special

12.	SEAT / DISK STACK MATERIAL		
	Seat	Disk stack	Cage guide
P2	CA40	SUS 420J2	CA40
R4	CF8M	316L SS	CF8M + HCr
YY	Special	Special	Special

13.	SEAT APPLICATION
X	Not Applicable
A	Cobalt based alloy
Y	Special

OTHERS

14.	PACKING / BELLOWS TYPE
S	General packing
E	Low emission, Live loaded
C	Bellows Seal (316L SS, Formed)
Y	Special

15.	PACKING MATERIAL
G	PTFE + Carbon fiber
F	Graphite
T	PTFE V-Ring
C	PTFE + Carbon fiber (ATEX)
H	Hi-Graphite
Y	Special

16.	SEAL RING MATERIAL
G	PTFE + Graphite
H	PTFE + Graphite + Carbon
M	Graphite
T	PTFE
X	Not applicable
Y	Special

17.	GASKET MATERIAL
S	S/W gasket type, 316L SS + Graphite
L	S/W gasket type, 316L SS + PTFE
H	S/W gasket type, 316L SS + Hi-Graphite
Y	Special

18.	STUD / NUT MATERIAL
G	A193 gr. B7M / A194 gr. 2HM
D	A193 gr. B8M / A194 gr. 8M
K	A320 gr. B8M cl. 2 / A194 gr. 8M
H	A193 gr. B16 / A194 gr. 7
E	A453 gr. 660 / A453 gr. 660
Y	Special

19.	OPTIONS
X	Not Applicable
E	Anti-erosion
L	Lub. & Isol. valve.
W	Water seal
Y	Special

- * ASME valve face to face length according to ISA 75.08. EN valve face to face length according to ASME CL300.
- * The body, bonnet, trim materials are subject to change as equivalent depending on detail design.
- * See 'Neles Globe Typecode Instruction' for further options and explanations.
- * Round bar material such as AISI 410SS (for A743 gr. CA 15), AISI 316SS (for A351 gr. CF8M), SUS420J2 (for A743 gr. CA40) and AISI 630SS (for A747 gr. CB7Cu-1) can be used depending on manufacturing process.

TRIM TYPE & RATED Cv

20. Sign	Trim type	21. Sign	Trim characteristic	22. Sign	Description	RATED Cv															
						Body Size and stroke															
						1" str.	1-1/2" str.	2" str.	3" str.	4" str.	6" str.	8" str.	10" str.	12" str.	14" str.	16" str.					
A	Balanced plug	E	Equal %	FG	Full capa. / Gas	5 (20)	10 (20)	18 (40)	38 (50)	60 (50)	104 (60)	176 (70)	268 (80)	390 (120)	540 (140)	710 (160)					
A	High temp. balanced plug			FL	Full capa. / Liquid																
				1G	1-Step red. / Gas	2.5 (20)	6 (20)	11 (40)	24 (50)	36 (50)	64 (60)	108 (70)	164 (80)	236 (120)	328 (140)	430 (160)					
P	Unbalanced plug			1L	1-Step red. / Liquid																
				2G	2-Step red. / Gas	1.2 (20)	3 (20)	5 (40)	12 (50)	18 (50)	32 (60)	54 (70)	82 (80)	118 (120)	164 (140)	214 (160)					
				2L	2-Step red. / Liquid																
				3G	3-Step red. / Gas	0.6 (20)	1.5 (20)	2 (40)	6 (50)	9 (50)	16 (60)	27 (70)	40 (80)	60 (120)	82 (140)	106 (160)					
				3L	3-Step red. / Liquid																
		L	Linear	FG	Full capa. / Gas	7 (20)	16 (20)	26 (40)	54 (50)	84 (50)	146 (60)	252 (70)	384 (80)	560 (120)	770 (140)	1020 (160)					
				FL	Full capa. / Liquid																
				1G	1-Step red. / Gas	3 (20)	8 (20)	12 (40)	28 (50)	52 (50)	90 (60)	156 (70)	234 (80)	340 (120)	470 (140)	624 (160)					
				1L	1-Step red. / Liquid																
				2G	2-Step red. / Gas	1.6 (20)	4 (20)	6 (40)	14 (50)	26 (50)	45 (60)	78 (70)	116 (80)	170 (120)	234 (140)	310 (160)					
				2L	2-Step red. / Liquid																
				3G	3-Step red. / Gas	0.8 (20)	2 (20)	3 (40)	7 (50)	14 (50)	22 (60)	40 (70)	58 (80)	84 (120)	116 (140)	154 (160)					
				3L	3-Step red. / Liquid																
Y	Special	Y	Special	YY	Special	Please contact Valmet for more information															

- Rated Cv is different depending on the trim type and characteristic.
- Str. : valve stroke length(mm). It should be matched with actuator stroke length.

Subject to change without prior notice.
 Neles, Neles Easyflow, Jamesbury, Stonel, Valvcon and Flowrox, and certain other trademarks, are either registered trademarks or trademarks of Valmet Oyj or its subsidiaries in the United States and/or in other countries.
 For more information www.neles.com/trademarks

Valmet Flow Control Oy
 Vanha Porvoontie 229, 01380 Vantaa, Finland.
 Tel. +358 10 417 5000.
www.valmet.com/flowcontrol

